

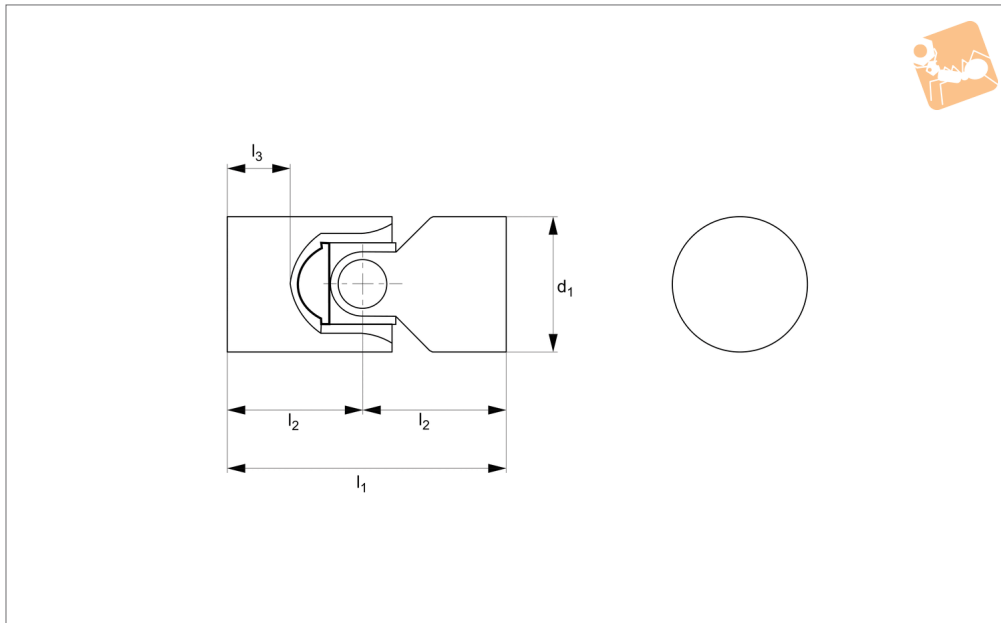

# Stainless 316 Single Universal Joint

Stainless unbored - solid ends

## Universal Joints



**R3698**

UNIVERSAL JOINTS

### Material

Stainless steel (AISI 316), bearing type: Plain bearing.

### Technical Notes

To DIN 808.  
Maximum bending angle 45° per joint.  
Max. drive speed of joints with journal bearings 100 rpm.

### Tips

Single universal joints are used where

shafts off-set towards each other.  
Product variations available on request: square bores and hex bores.  
Can be disassembled to aid machining of ends.

### Assembly instructions:

Step 1: Spray with grease internal high load spray adhesive (type TG248) ball and holes in the forks.  
Step 2: Place sphere inside fork 1 and insert long pin with planes oriented

towards perpendicular hole in the sphere.  
Step 3: Insert fork 2 on the ball and fit inside the short flared pin subsequently, on the opposite side, the short threaded pin.  
Step 4: Place the countersunk screw tightening it adequately.  
Step 5: Screw the locking dowel on the pin short threaded against the screw.

Order No.	d <sub>1</sub>	l <sub>1</sub>	l <sub>2</sub>	l <sub>3</sub>
R3698.020-UN	20	62	31	19
R3698.025-UN	25	74	37	23
R3698.032-UN	32	86	43	25
R3698.040-UN	40	108	54	30
R3698.050-UN	50	132	66	40

