

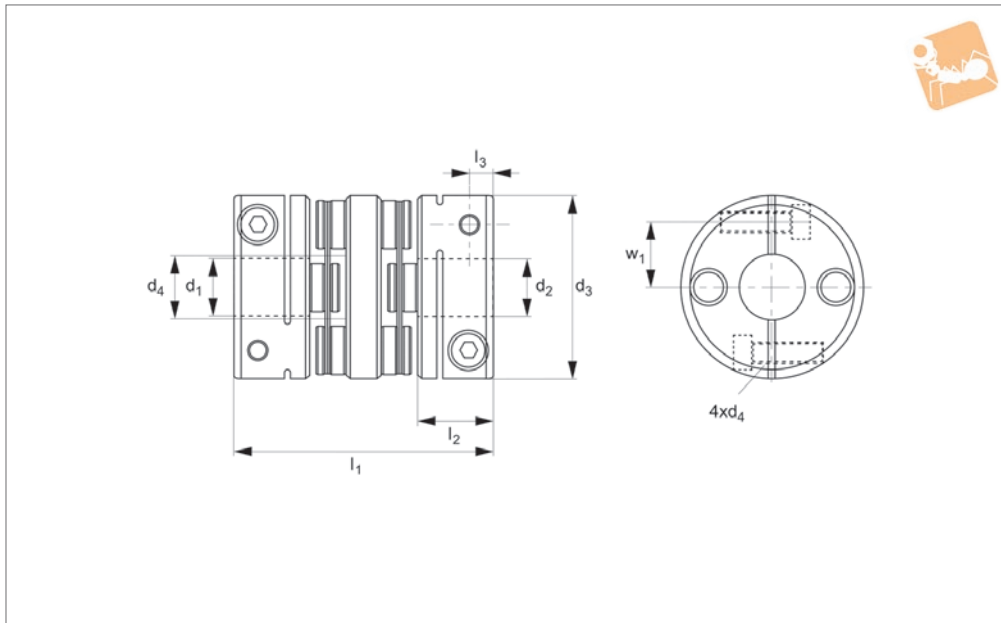

# Double Disk Coupling - Aluminium

clamping type, long type.

Flexible Couplings

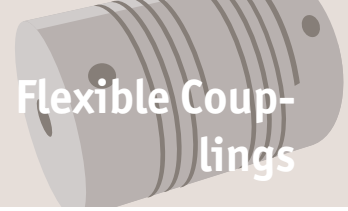

**R3066.1**

FLEXIBLE COUPLINGS

**Material**

Main frame: Anodized aluminium AL7075  
 Disk: Stainless steel SUS301  
 Pin: Stainless steel SUS303

**Technical Notes**

High wrench torque load, high wrench torque rigidity capacity and excellent sensibility.

The flexure allowed by stainless steel disc portion of the coupling is capable of accommodating angular, parallel and axial misalignment. Teethless screw to lock disks, zero backlash Clockwise character is exactly the same as anti-clockwise one. Free maintenance, oil-resist and anti

corrosiveness. Offset of angular, parallel or axial deviation are individual allowed value, so couple reasons of axial offset appearing at same time would reduce the unit allowable value.

Order No.	d <sub>1</sub> & d <sub>2</sub> tol. h8	d <sub>3</sub>	d <sub>4</sub>	d <sub>5</sub>	l <sub>1</sub>	l <sub>2</sub>	l <sub>3</sub>	w <sub>1</sub>	Clamping screw lock torque Nm
R3066.A-4	4	19	8.5	M2	28	8	2.5	6.5	0.5
R3066.A-4.5	4.5	19	8.5	M2	28	8	2.5	6.5	0.5
R3066.A-5	4.5	19	8.5	M2	28	8	2.5	6.5	0.5
R3066.A-6	6	19	8.5	M2	28	8	2.5	6.5	0.5
R3066.A-7	7	19	8.5	M2	28	8	2.5	6.5	0.5
R3066.A-8	8	19	8.5	M2	28	8	2.5	6.5	0.5
R3066.B-6	6	25	12.5	M2,5	31	10	3.5	9	1
R3066.B-7	7	25	12.5	M2,5	31	10	3.5	9	1
R3066.B-8	8	25	12.5	M2,5	31	10	3.5	9	1
R3066.B-10	10	25	12.5	M2,5	31	10	3.5	9	1
R3066.B-11	11	25	12.5	M2,5	31	10	3.5	9	1
R3066.B-12	12	25	12.5	M2,5	31	10	3.5	9	1
R3066.C-8	8	32	16	M3	40	12	4	11	1.5
R3066.C-10	10	32	16	M3	40	12	4	11	1.5
R3066.C-11	11	32	16	M3	40	12	4	11	1.5
R3066.C-12	12	32	16	M3	40	12	4	11	1.5
R3066.C-14	14	32	16	M3	40	12	4	11	1.5
R3066.C-15	15	32	16	M3	40	12	4	11	1.5