

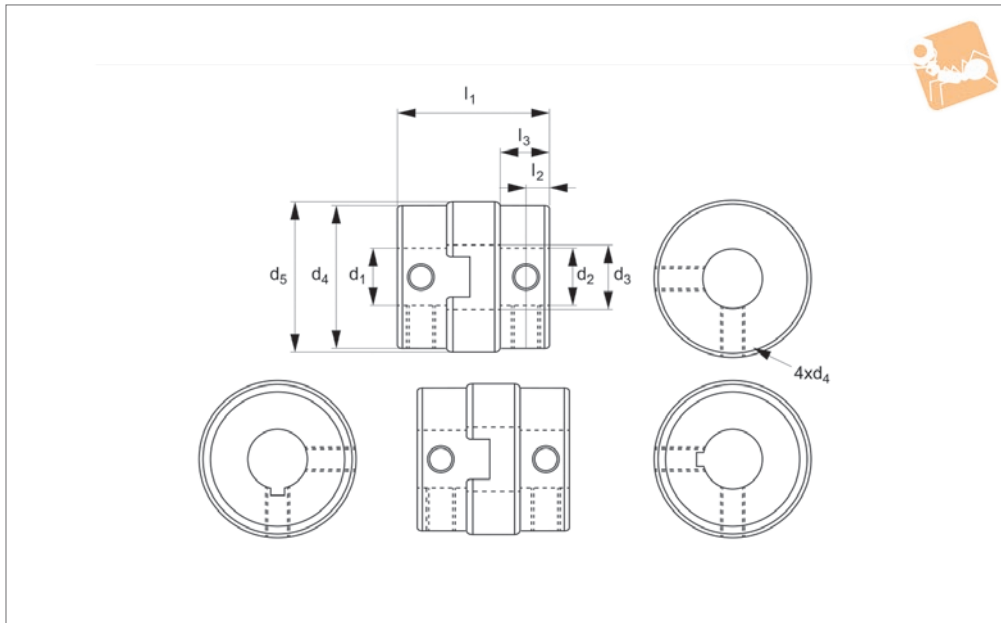

Oldham Coupling with Aluminium Bronze Insert

Flexible Couplings

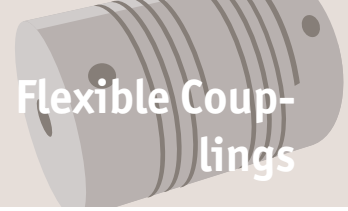

R3053.1

FLEXIBLE COUPLINGS

Material

Mainframe: Stainless steel alloy SUS304
Insert: Aluminium bronze (filled with solid lubricant)

individual allowed value, so couple reasons of axial offset appearing at same time would reduce the unit allowable value.

Suit for high wrench torque, high rotation. In case of parallel deviation over 0,1, abra-

sion of the insert is direct ratio to load torque, offset and rotation numbers. Available options for key way inner diameter is bigger than 6mm.

Technical Notes

Offset of angular or axial deviation are

Order No.	Dia. Ø nom.	d ₁ & d ₂	d ₃	d ₄	d ₅	l ₁	l ₂	l ₃	Clamping screw lock torque Nm	Clamping screw d ₆
R3053.A-4	15	4	7.2	14.5	15	16	2.6	5.4	0.7	M 3
R3053.A-5	15	5	7.2	14.5	15	16	2.6	5.4	0.7	M 3
R3053.A-6	15	6	7.2	14.5	15	16	2.6	5.4	0.7	M 3
R3053.A-7	15	7	7.2	14.5	15	16	2.6	5.4	0.7	M 3
R3053.A-8	15	8	7.2	14.5	15	16	2.6	5.4	0.7	M 3
R3053.B-5	17	5	8.2	16.8	17.5	19.8	3.2	6.7	1.17	M 4
R3053.B-6	17	6	8.2	16.8	17.5	19.8	3.2	6.7	1.17	M 4
R3053.B-7	17	7	8.2	16.8	17.5	19.8	3.2	6.7	1.17	M 4
R3053.B-8	17	8	8.2	16.8	17.5	19.8	3.2	6.7	1.17	M 4
R3053.C-6	20	6	9	20	21	21.6	3.4	7	1.7	M 4
R3053.C-7	20	7	9	20	21	21.6	3.4	7	1.7	M 4
R3053.C-8	20	8	9	20	21	21.6	3.4	7	1.7	M 4
R3053.C-10	20	10	9	20	21	21.6	3.4	7	1.7	M 4
R3053.C-11	20	11	9	20	21	21.6	3.4	7	1.7	M 4
R3053.C-12	20	12	9	20	21	21.6	3.4	7	1.7	M 4
R3053.D-6	26	6	12	26	27	25.6	4	9	1.7	M 4
R3053.D-7	26	7	12	26	27	25.6	4	9	1.7	M 4
R3053.D-8	26	8	12	26	27	25.6	4	9	1.7	M 4
R3053.D-10	26	10	12	26	27	25.6	4	9	1.7	M 4
R3053.D-11	26	11	12	26	27	25.6	4	9	1.7	M 4
R3053.D-12	26	12	12	26	27	25.6	4	9	1.7	M 4
R3053.D-14	26	14	12	26	27	25.6	4	9	1.7	M 4