

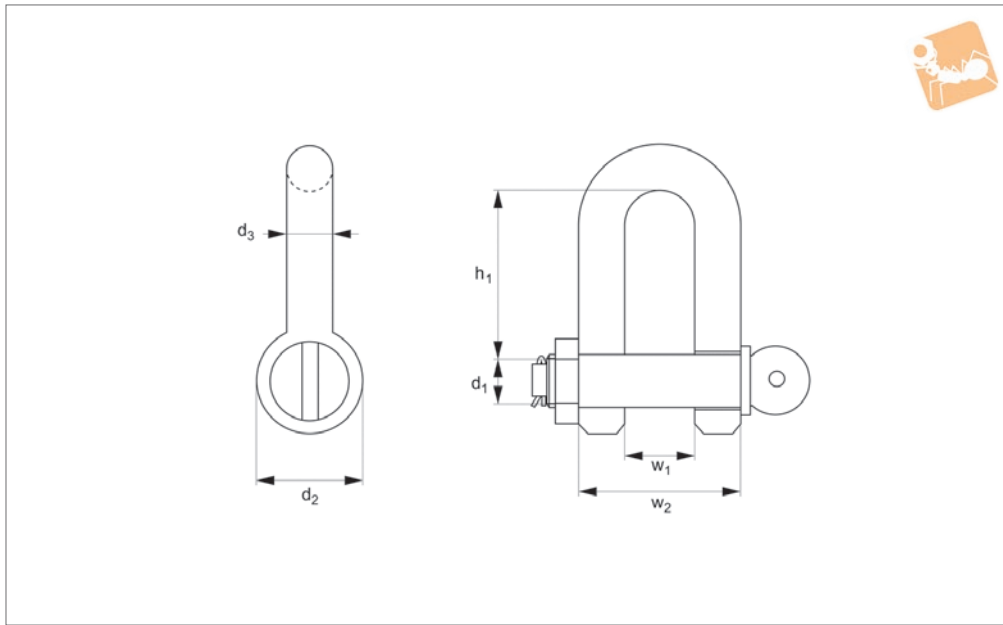

Steel Shackles with split pin

Lifting Pins, Lifting Bolts &



P4082

LIFTING PINS, LIFTING BOLTS & SWING BOLTS

Material

Steel, zinc plated.

Technical Notes

To DIN 82101 Form C.

| Order No. | Material | d ₁ | d ₂ | d ₃ | h ₁ | w ₁ | w ₂ | Load kg max. | Weight kg |
|-----------|----------|----------------|----------------|----------------|----------------|----------------|----------------|--------------------|--------------|
| P4082.10 | Steel | 10 | 20 | 8 | 30.0 | 14 | 30 | 400 | 0.10 |
| P4082.12 | Steel | 12 | 24 | 10 | 36.0 | 17 | 37 | 630 | 0.18 |
| P4082.16 | Steel | 16 | 32 | 13 | 49.0 | 21 | 47 | 1000 | 0.39 |
| P4082.20 | Steel | 20 | 40 | 17 | 61.0 | 27 | 61 | 1600 | 0.80 |
| P4082.22 | Steel | 22 | 44 | 19 | 67.0 | 30 | 68 | 2000 | 1.08 |
| P4082.24 | Steel | 24 | 48 | 21 | 73.0 | 33 | 75 | 2500 | 1.40 |
| P4082.27 | Steel | 27 | 54 | 24 | 85.5 | 38 | 86 | 3150 | 2.00 |
| P4082.30 | Steel | 30 | 60 | 27 | 91.0 | 42 | 96 | 4000 | 2.70 |
| P4082.36 | Steel | 36 | 72 | 30 | 111.0 | 47 | 107 | 5000 | 4.30 |
| P4082.39 | Steel | 39 | 78 | 34 | 119.5 | 53 | 121 | 6300 | 5.80 |
| P4082.45 | Steel | 45 | 90 | 38 | 139.5 | 60 | 136 | 8000 | 8.50 |
| P4082.48 | Steel | 48 | 96 | 42 | 147.0 | 66 | 150 | 10000 | 10.8 |
| P4082.52 | Steel | 52 | 104 | 47 | 158.0 | 73 | 167 | 12500 | 14.4 |
| P4082.60 | Steel | 60 | 120 | 52 | 185.0 | 81 | 185 | 16000 | 20.5 |
| P4082.68 | Steel | 68 | 136 | 58 | 211.0 | 90 | 206 | 20000 | 29.5 |
| P4082.72 | Steel | 72 | 144 | 63 | 221.0 | 100 | 226 | 25000 | 36.0 |
| P4082.80 | Steel | 80 | 160 | 70 | 246.0 | 110 | 250 | 31500 | 49.5 |
| P4082.90 | Steel | 90 | 180 | 79 | 276.0 | 125 | 283 | 40000 | 69.0 |