

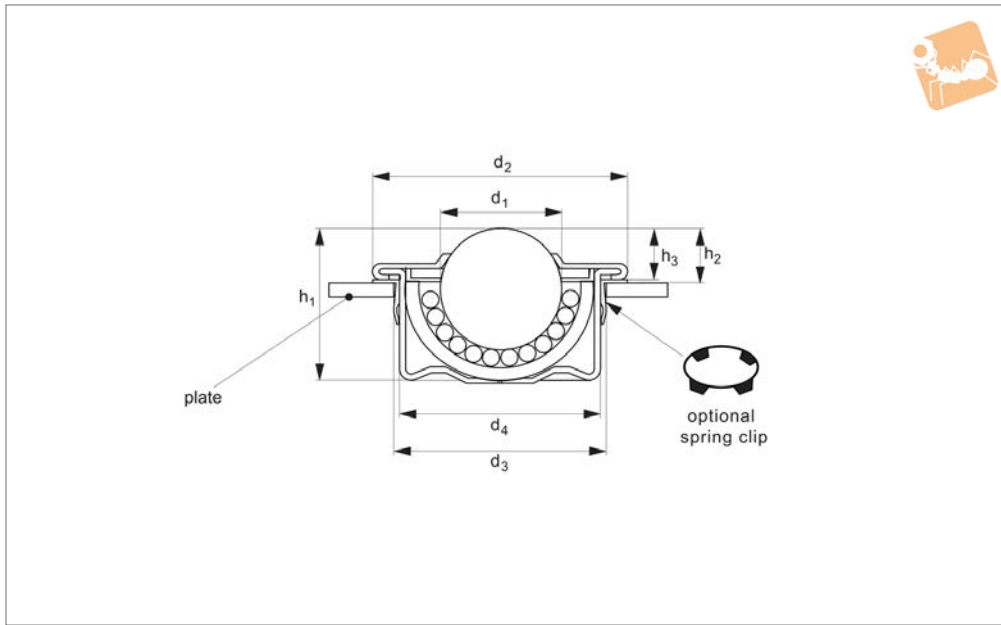

# Push-Fit Ball Transfer Units

light duty, push fit



**P2700.AV**

MATERIAL HANDLING

### Material

Steel (zinc plated), stainless steel (AISI 416 for housing and AISI 420 for balls) and acetal (POM).

### Technical Notes

Cost-effective and light-weight units formed from sheet steel material. No reduction in load carrying capacity even

when installed upside down. Sizes 22 and 30 have a felt seal for the ball. Low friction 1:0,03, speeds up to 1m/s. Temperature range -20°C to +70°C.

### Tips

To compensate for irregular bore diameters we recommend using the spring clip (stainless) part no. P2730.

Clip requires a minimum plate thickness of 3mm to grip securely. These rollers can only be used in the horizontal or „ball up“ direction.

Order No.	$d_1$	$d_2$	$h_1$	$h_2$	$d_3$ min.	$d_3$ max.	$d_4$	$h_3$	Housing	Ball	Load kg max.
P2700.150-CC	15	31	21	10.1	25	25.5	24	9.8	Steel	Steel	60
P2700.150-CS	15	31	21	10.1	25	25.5	24	9.8	Steel	Stainless	60
P2700.150-CA	15	31	21	10.1	25	25.5	24	9.8	Steel	Acetal	10
P2700.150-SS	15	31	21	10.1	25	25.5	24	9.8	Stainless	Stainless	40
P2700.220-CC	22	45	29.5	10.4	37.0	37.5	36	10.1	Steel	Steel	160
P2700.220-CS	22	45	29.5	10.4	37.0	37.5	36	10.1	Steel	Stainless	160
P2700.220-CA	22	45	29.5	10.4	37.0	37.5	36	10.1	Steel	Acetal	20
P2700.220-SS	22	45	29.5	10.4	37.0	37.5	36	10.1	Stainless	Stainless	90
P2700.300-CC	30	55	37	14.4	46	46.5	45	14.1	Steel	Steel	280
P2700.300-CS	30	55	37	14.4	46	46.5	45	14.1	Steel	Stainless	280
P2700.300-CA	30	55	37	14.4	46	46.5	45	14.1	Steel	Acetal	25
P2700.300-SS	30	55	37	14.4	46	46.5	45	14.1	Stainless	Stainless	200



## Product selection

### Available materials

Housing	Ball	Load Factor	
Steel	Steel	1,0	Housing: AISI 1040 steel, machined, toughened & zinc plated. Ball: AISI 52100 chrome steel
Steel	Stainless	0,7	Housing: AISI 1040 steel, machined, toughened & zinc plated. Ball: AISI 420 stainless steel
Stainless	Stainless	0,7	Housing: AISI 416 stainless steel. Ball: AISI 420 stainless steel
Steel	Acetal		Housing: AISI 1040 steel, machined, toughened & zinc plated. Ball: POM acetal
Aluminium	Stainless		Housing: aluminium. Ball: AISI 420 stainless steel
Acetal	Acetal		Housing: POM acetal. Ball: POM acetal
Acetal	Stainless		Housing: POM acetal. Ball: AISI 420 stainless steel

### Fixing clip selection

Part No.	Ball Size	Minimum Bore ø	Maximum Bore ø
67202.W9015	15	24,8	25,0
67202.W9022	22	37,0	37,2
67202.W9030	30	46,3	46,7

Clip requires a minimum plate thickness of 3mm to grip securely

### How to select the correct unit

Ball Type	Max Load (Kg)	Friction (% of load)	Speed (m/s)	Shock Loads	Arduous Conditions	Orientation	Instant Change
Medium Duty	20-3500	2%	1,5	✓✓✓	✓✓		✓✓✓
Light Duty	7-250	3%	1,0	✓	✓✓		✓✓✓

### Variables to consider



**Shock Loads:**  
Specify High Capacity series & spring loaded units



**Track Hardness/Conveyed Item Material:**  
Standard material ball units have Rockwell 'C' hardness of 60 minimum



**Delicate Surfaces:**  
Ball Units - Acetal (POM) & Phenolic Resin



**Operating Environment:**  
Wet, dirty, outdoor, radioactive

### Operation temperature

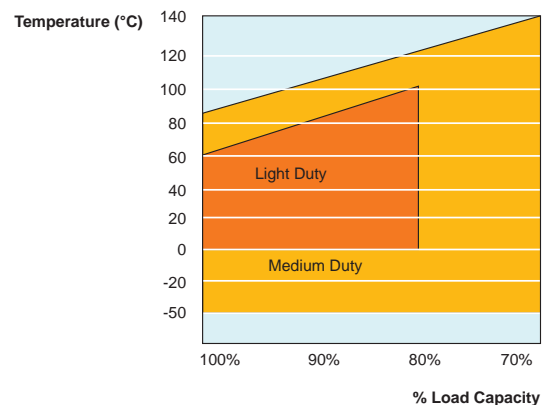

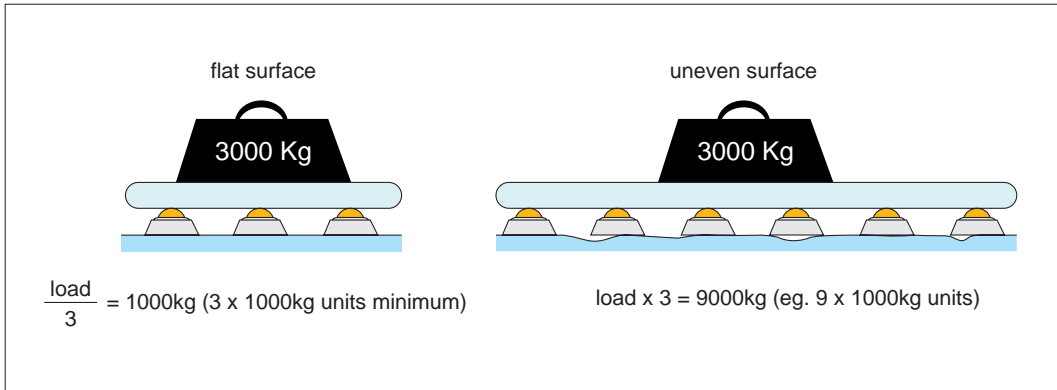

## Load and stability

To determine the load of a ball transfer unit, the weight of the article to be conveyed should be divided by 3. If the height tolerance of the load balls is good and the surface of the workpiece to be conveyed is suitable, the calculation can be based on the number of ball transfer units under the load.

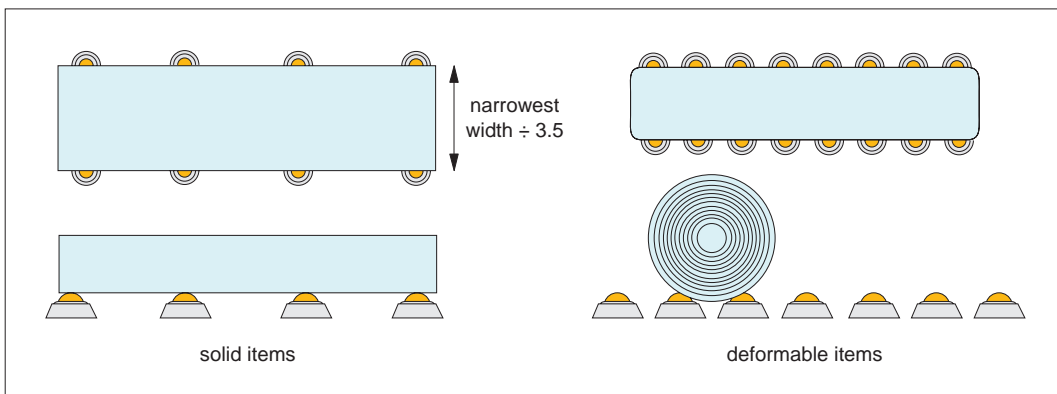

## Pitching and spacing

How the ball transfer units should be arranged depends on the bottom surface of the load to be transported. For loads with a uniform, even bottom surface, e.g. packing cases, the distance between the ball transfer units is calculated by dividing the smallest dimension by 3,5.

The maximum conveying speed allowed amounts to 2m/s. The load capacities specified apply to any mounting position and are based on  $10^6$  rotations of the load ball. With the units being used over a longer time at speeds exceeding 1m/s, an increase in temperature as well as a reduction in travel life must be expected depending on the load.

## Conveying speed and load capacity

$$L = \frac{C^3}{F} 10^6 \text{ rotations}$$

L = travel life  
C = load capacity (N)  
F = load (N)

## Calculation of travel life

The diagram shows the friction values as a function of load and speed for ball transfer units. These approximate values apply to all mounting positions with operation on a hardened steel plate.

v = 1m/s

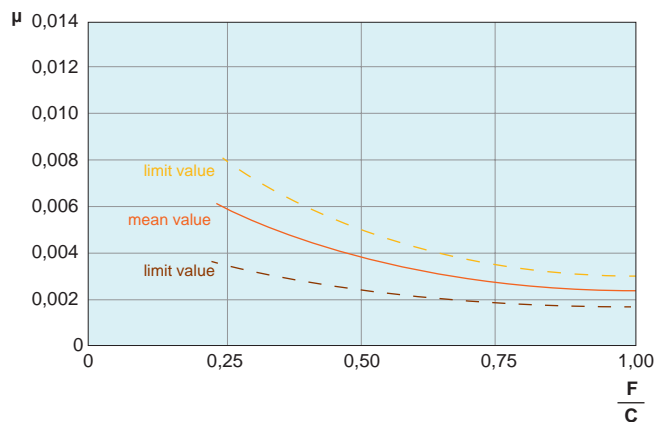

## Friction