



Levelling Feet

plastic pad, bolt steel



Levelling Feet

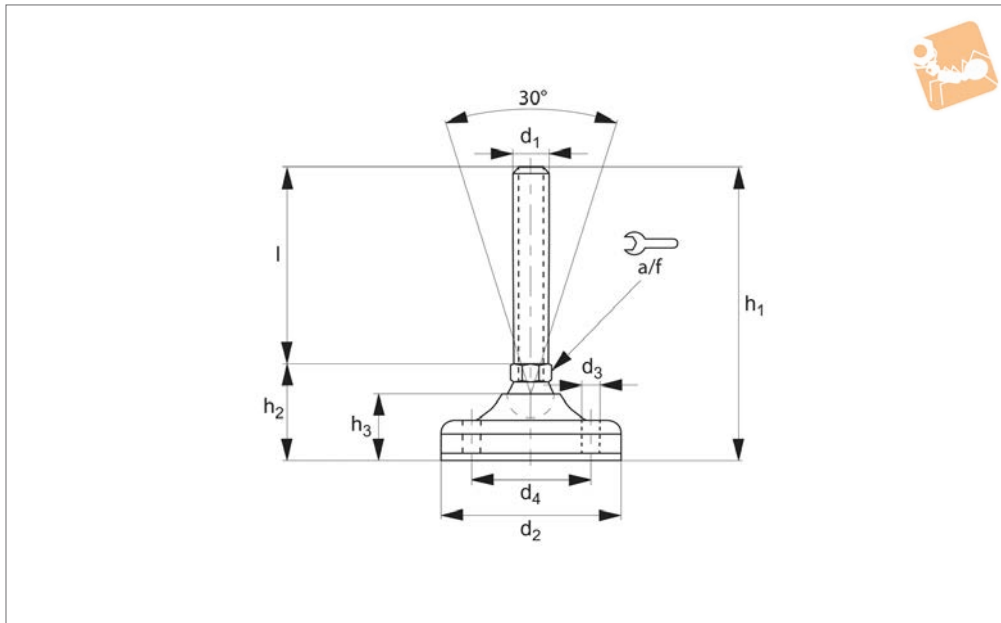

P2205.2

LEVELLING FEET

Material

Pad: polyamide reinforced by fibre glass with anti-slip pad.
Bolt: steel (C40)

Technical Notes

Load values refer to static loads, located at half the screw height.
When vibrations or dynamic loads are

present these values should be reduced.

Order No.	d ₁	d ₂	d ₃	d ₄	l	h ₁	h ₂	h ₃	A/F	Load kN max.
P2205.083-10-050	M10	83	8.5	55	50	91	41	30	14	15
P2205.083-10-075	M10	83	8.5	55	75	116	41	30	14	15
P2205.083-10-100	M10	83	8.5	55	100	141	41	30	14	15
P2205.083-10-125	M10	83	8.5	55	125	166	41	30	14	15
P2205.083-12-050	M12	83	8.5	55	50	91	41	30	14	15
P2205.083-12-075	M12	83	8.5	55	75	116	41	30	14	15
P2205.083-12-100	M12	83	8.5	55	100	141	41	30	14	15
P2205.083-12-125	M12	83	8.5	55	125	161	41	30	14	15
P2205.083-14-050	M14	83	8.5	55	50	91	41	30	14	20
P2205.083-14-075	M14	83	8.5	55	75	116	41	30	14	20
P2205.083-14-100	M14	83	8.5	55	100	141	41	30	14	20
P2205.083-14-125	M14	83	8.5	55	125	166	41	30	14	20
P2205.083-14-150	M14	83	8.5	55	150	191	41	30	14	20
P2205.083-14-175	M14	83	8.5	55	175	216	41	30	14	20
P2205.083-16-050	M16	83	8.5	55	50	91	41	30	16	20
P2205.083-16-075	M16	83	8.5	55	75	116	41	30	16	20
P2205.083-16-100	M16	83	8.5	55	100	141	41	30	16	20
P2205.083-16-125	M16	83	8.5	55	125	166	41	30	16	20
P2205.083-16-150	M16	83	8.5	55	150	191	41	30	16	20
P2205.083-16-175	M16	83	8.5	55	175	216	41	30	16	20
P2205.083-16-200	M16	83	8.5	55	200	241	41	30	16	20
P2205.083-20-075	M20	83	8.5	55	75	119	44	30@	17	20
P2205.083-20-100	M20	83	8.5	55	100	144	44	30	17	20
P2205.083-20-125	M20	83	8.5	55	125	169	44	30	17	20
P2205.083-20-150	M20	83	8.5	55	150	194	44	30	17	20
P2205.083-20-175	M20	83	8.5	55	175	219	44	30	17	20
P2205.083-20-200	M20	83	8.5	55	200	244	44	30	17	20
P2205.083-20-225	M20	83	8.5	55	225	269	44	30	17	20



All levelling feet can be produced with the following fixing types:

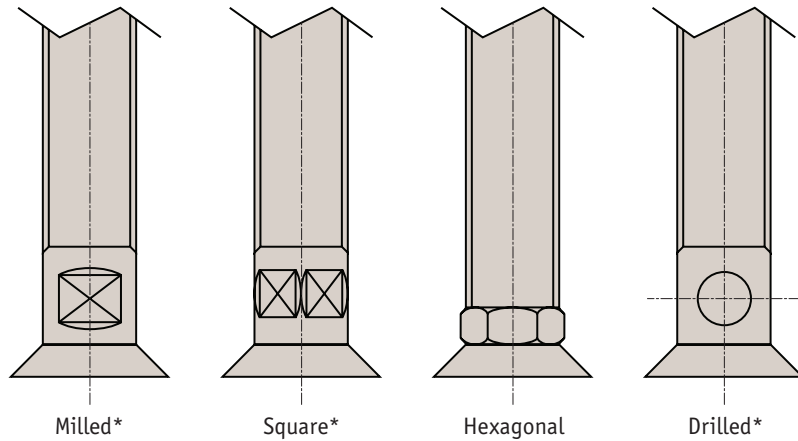
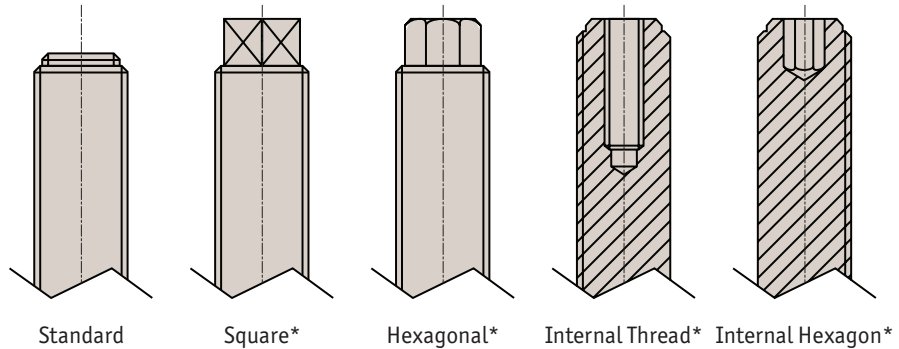

Thread versions

- Metric thread - coarse pitch (standard)
- Metric thread - fine pitch
- Thread gas 55°
- Imperial thread Unc
- Whitworth thread

* For non-standard threads a minimum order will apply.

Levelling Feet from Automation Components

LEVELLING FEET