



# Levelling Feet - Heavy Duty

bolt down option, bolt stainless steel



## Levelling Feet

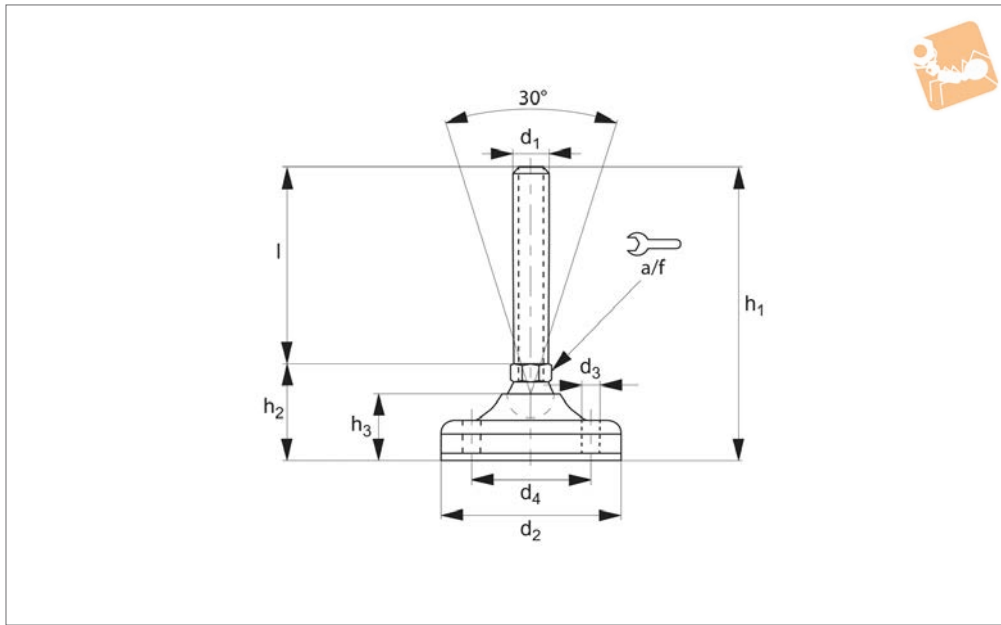

**P2203.3**

LEVELLING FEET

### Material

Pad: polyamide reinforced by fibre glass with anti-slip pad.  
Bolt: stainless steel AISI 304.

### Technical Notes

Load values refer to static loads, located at half the screw height.  
When vibrations or dynamic loads are

present these values should be reduced.  
Larger pad size allows for bolt down holes to be drilled through.

Order No.	d <sub>1</sub>	d <sub>2</sub>	l	d <sub>3</sub>	d <sub>4</sub>	h <sub>1</sub>	h <sub>2</sub>	h <sub>3</sub>	A/F	Load kN max.
P2203.123-16-050	M16	123	50	12.5	87	110	60	40	20	35
P2203.123-16-075	M16	123	75	12.5	87	135	60	40	20	35
P2203.123-16-100	M16	123	100	12.5	87	160	60	40	20	35
P2203.123-16-125	M16	123	125	12.5	87	185	60	40	20	35
P2203.123-16-150	M16	123	150	12.5	87	210	60	40	20	35
P2203.123-16-175	M16	123	175	12.5	87	235	60	40	20	35
P2203.123-16-200	M16	123	200	12.5	87	260	60	40	20	35
P2203.123-16-225	M16	123	225	12.5	87	285	60	40	20	35
P2203.123-20-075	M20	123	75	12.5	87	135	60	40	20	35
P2203.123-20-100	M20	123	100	12.5	87	160	60	40	20	35
P2203.123-20-125	M20	123	125	12.5	87	185	60	40	20	35
P2203.123-20-150	M20	123	150	12.5	87	210	60	40	20	35
P2203.123-20-175	M20	123	175	12.5	87	235	60	40	20	35
P2203.123-20-200	M20	123	200	12.5	87	260	60	40	20	35
P2203.123-20-225	M20	123	225	12.5	87	285	60	40	20	35
P2203.123-20-250	M20	123	250	12.5	87	310	60	40	20	35
P2203.123-24-075	M24	123	75	12.5	87	135	60	40	20	35
P2203.123-24-100	M24	123	100	12.5	87	160	60	40	20	35
P2203.123-24-125	M24	123	125	12.5	87	185	60	40	20	35
P2203.123-24-150	M24	123	150	12.5	87	210	60	40	20	35
P2203.123-24-175	M24	123	175	12.5	87	235	60	40	20	35
P2203.123-24-200	M24	123	200	12.5	87	260	60	40	20	35
P2203.123-24-225	M24	123	225	12.5	87	285	60	40	20	35
P2203.123-24-250	M24	123	250	12.5	87	310	60	40	20	35
P2203.123-30-100	M30	123	100	12.5	87	161	61	40	26	35
P2203.123-30-125	M30	123	125	12.5	87	186	61	40	26	35
P2203.123-30-150	M30	123	150	12.5	87	211	61	40	26	35
P2203.123-30-175	M30	123	175	12.5	87	236	61	40	26	35
P2203.123-30-200	M30	123	200	12.5	87	261	61	40	26	35
P2203.123-30-225	M30	123	225	12.5	87	286	61	40	26	35
P2203.123-30-250	M30	123	250	12.5	87	311	61	40	26	35



All levelling feet can be produced with the following fixing types:

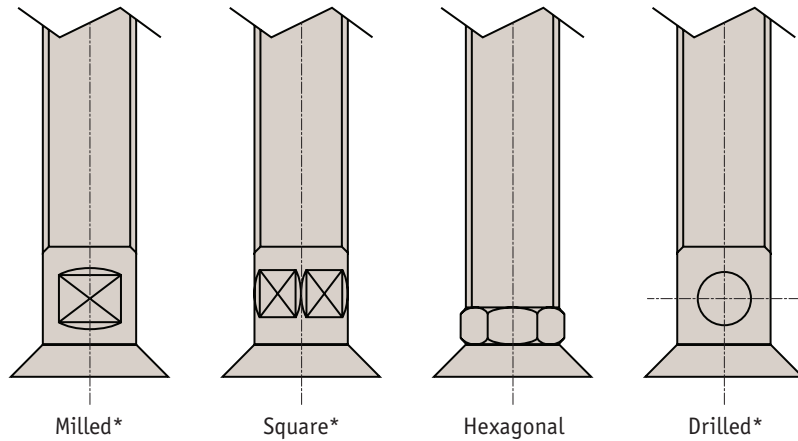
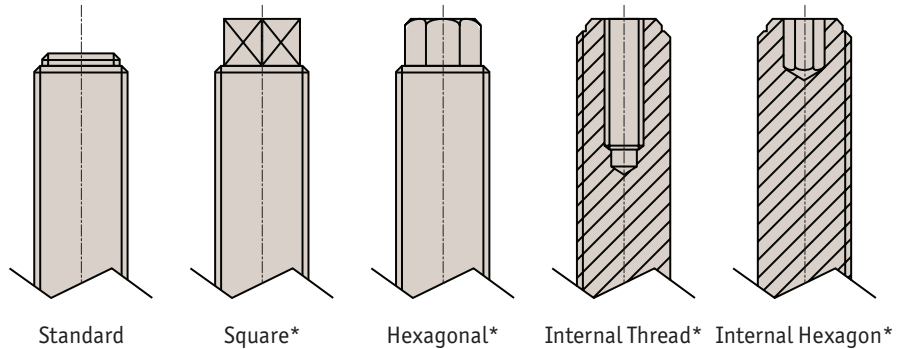

**Thread versions**

- Metric thread - coarse pitch (standard)
- Metric thread - fine pitch
- Thread gas 55°
- Imperial thread Unc
- Whitworth thread

\* For non-standard threads a minimum order will apply.

Levelling Feet from Automation Components

LEVELLING FEET