



Levelling Feet

bolt stainless steel



Levelling Feet

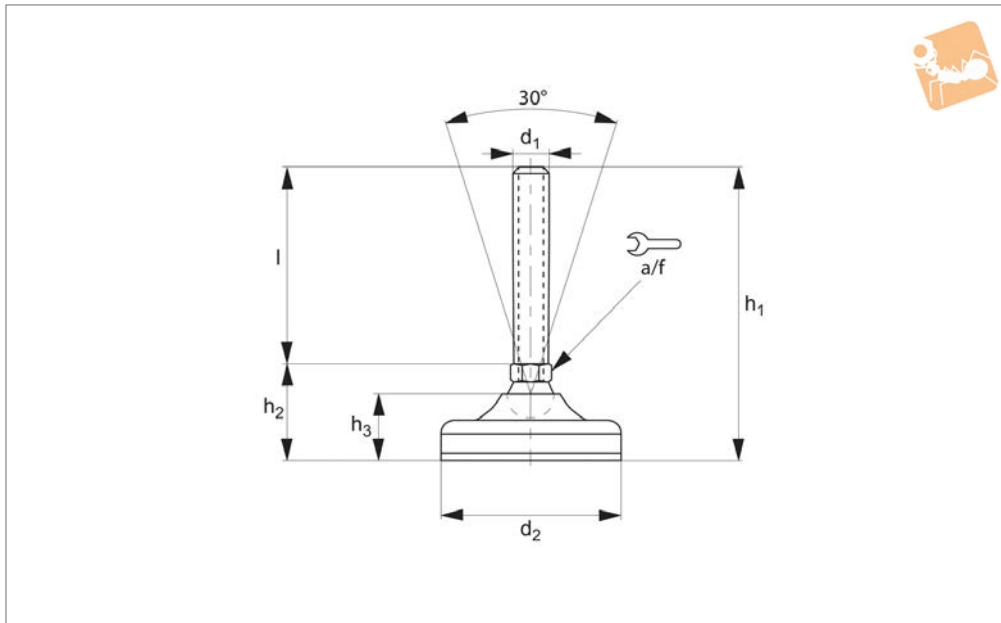

P2203.1

LEVELLING FEET

Material

Pad: polyamide reinforced by fibre glass with anti-slip pad.
Bolt: stainless steel AISI 304.

Technical Notes

Load values refer to static loads, located at half the screw height.
When vibrations or dynamic loads are

present these values should be reduced.

Order No.	d ₁	d ₂	l	h ₁	h ₂	h ₃	A/F	Load kN max.
P2203.040-08-050	M 8	40	50	80	30	19.5	12	10
P2203.040-08-100	M 8	40	100	130	30	19.5	12	10
P2203.065-10-075	M10	65	75	111	36	26.0	14	11
P2203.065-10-100	M10	65	100	136	36	26.0	14	11
P2203.065-10-125	M10	65	125	161	36	26.0	14	11
P2203.065-12-050	M12	65	50	86	36	26.0	14	11
P2203.065-12-075	M12	65	75	111	36	26.0	14	11
P2203.065-12-100	M12	65	100	136	36	26.0	14	11
P2203.065-14-050	M14	65	50	86	36	26.0	14	15
P2203.065-14-075	M14	65	75	111	36	26.0	14	15
P2203.065-14-100	M14	65	100	136	36	26.0	14	15
P2203.065-14-125	M14	65	125	161	36	26.0	14	15
P2203.065-14-150	M14	65	150	186	36	26.0	14	15
P2203.065-14-175	M14	65	175	211	36	26.0	14	15
P2203.065-16-050	M16	65	50	90	40	26.0	13	15
P2203.065-16-075	M16	65	75	115	40	26.0	13	15
P2203.065-16-100	M16	65	100	140	40	26.0	13	15
P2203.065-16-125	M16	65	125	165	40	26.0	13	15
P2203.065-16-150	M16	65	150	190	40	26.0	13	15
P2203.065-16-175	M16	65	175	215	40	26.0	13	15
P2203.065-16-200	M16	65	200	240	40	26.0	13	15
P2203.065-20-050	M20	65	50	90	40	26.0	17	15
P2203.065-20-075	M20	65	75	115	40	26.0	17	15
P2203.065-20-100	M20	65	100	140	40	26.0	17	15
P2203.065-20-125	M20	65	125	165	40	26.0	17	15
P2203.065-20-150	M20	65	150	190	40	26.0	17	15
P2203.065-20-175	M20	65	175	215	40	26.0	17	15
P2203.065-20-200	M20	65	200	240	40	26.0	17	15



All levelling feet can be produced with the following fixing types:

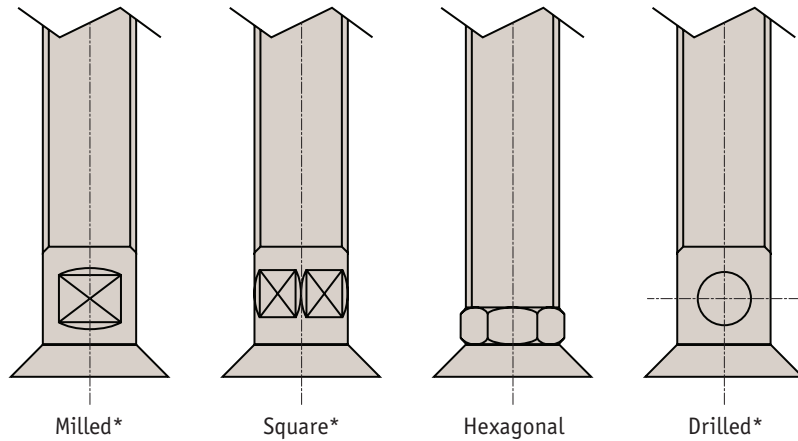
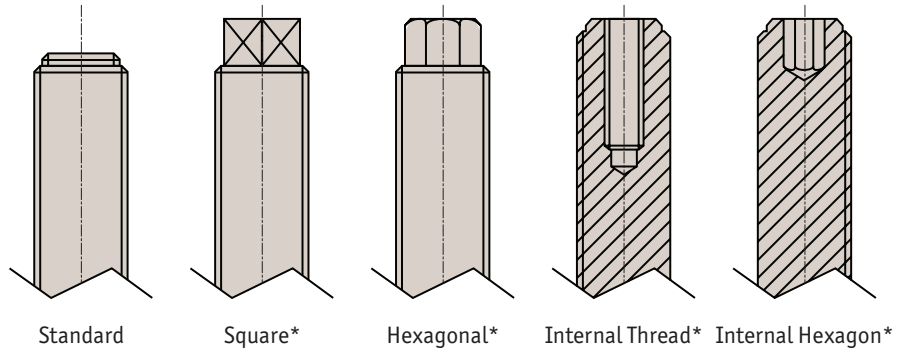

Thread versions

- Metric thread - coarse pitch (standard)
- Metric thread - fine pitch
- Thread gas 55°
- Imperial thread Unc
- Whitworth thread

* For non-standard threads a minimum order will apply.

Levelling Feet from Automation Components

LEVELLING FEET