

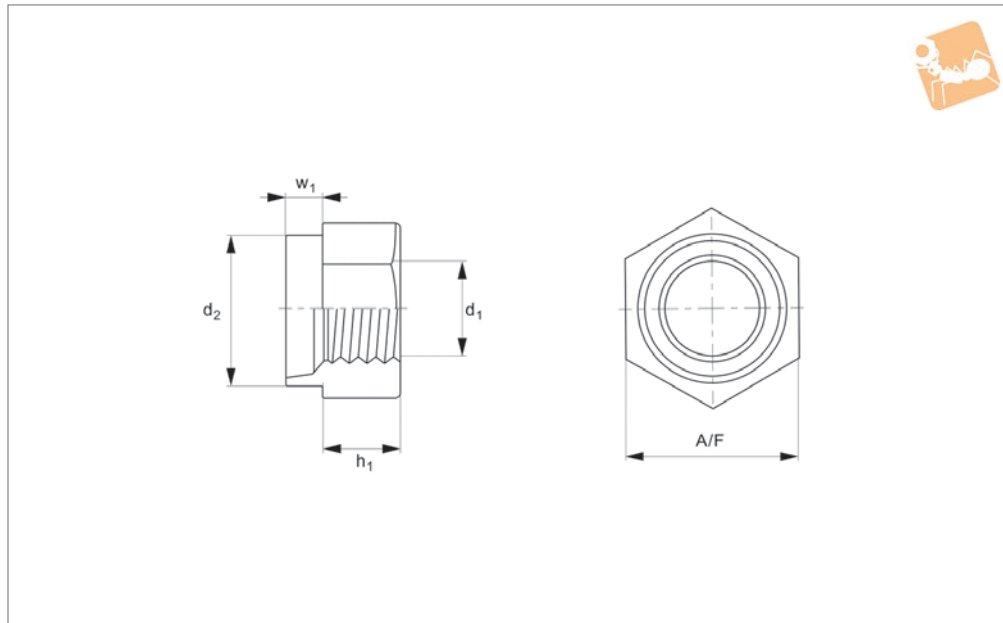

Hexagon Rivet Bushes

A2 stainless

Rivet Bushes



P0827.A2

RIVET BUSHES

Material

Stainless steel (A2, AISI 303).

Technical Notes

Rivet bushes are securely locked by means

of a thin spigot. For hexagon rivet bushes, the presence of undercut points provides further turning resistance.

These bushes can be installed by a press or

using a hammer.

| Order No. | d ₁ | Panel thickness | w ₁ | d ₂ | A/F | h ₁ | For gauge |
|------------------|----------------|-----------------|----------------|----------------|-------|----------------|-----------|
| P0827.030-22G-A2 | M 3 | 0.8 | 1,3-1,5 | 5.54 | 7.92 | 3.17 | 22G |
| P0827.030-20G-A2 | M 3 | 1.0 | 1,5-1,7 | 5.54 | 7.92 | 3.17 | 20G |
| P0827.030-18G-A2 | M 3 | 1.2 | 1,7-1,9 | 5.54 | 7.92 | 3.17 | 18G |
| P0827.030-16G-A2 | M 3 | 1.5 | 2,0-2,2 | 5.54 | 7.92 | 3.17 | 16G |
| P0827.030-14G-A2 | M 3 | 2.0 | 2,5-2,7 | 5.54 | 7.92 | 3.17 | 14G |
| P0827.030-12G-A2 | M 3 | 2.5 | 3,0-3,2 | 5.54 | 7.92 | 3.17 | 12G |
| P0827.030-10G-A2 | M 3 | 3.0 | 3,5-3,7 | 5.54 | 7.92 | 3.17 | 10G |
| P0827.030-08G-A2 | M 3 | 4.0 | 4,5-4,7 | 5.54 | 7.92 | 3.17 | 8G |
| P0827.040-22G-A2 | M 4 | 0.8 | 1,3-1,5 | 6.73 | 7.92 | 3.17 | 22G |
| P0827.040-20G-A2 | M 4 | 1.0 | 1,5-1,7 | 6.73 | 7.92 | 3.17 | 20G |
| P0827.040-18G-A2 | M 4 | 1.2 | 1,7-1,9 | 6.73 | 7.92 | 3.17 | 18G |
| P0827.040-16G-A2 | M 4 | 1.5 | 2,0-2,2 | 6.73 | 7.92 | 3.17 | 16G |
| P0827.040-14G-A2 | M 4 | 2.0 | 2,5-2,7 | 6.73 | 7.92 | 3.17 | 14G |
| P0827.040-12G-A2 | M 4 | 2.5 | 3,0-3,2 | 6.73 | 7.92 | 3.17 | 12G |
| P0827.040-10G-A2 | M 4 | 3.0 | 3,5-3,7 | 6.73 | 7.92 | 3.17 | 10G |
| P0827.040-08G-A2 | M 4 | 4.0 | 4,5-4,7 | 6.73 | 7.92 | 3.17 | 8G |
| P0827.050-22G-A2 | M 5 | 0.8 | 1,3-1,5 | 7.92 | 9.52 | 3.81 | 22G |
| P0827.050-20G-A2 | M 5 | 1.0 | 1,5-1,7 | 7.92 | 9.52 | 3.81 | 20G |
| P0827.050-18G-A2 | M 5 | 1.2 | 1,7-1,9 | 7.92 | 9.52 | 3.81 | 18G |
| P0827.050-16G-A2 | M 5 | 1.5 | 2,0-2,2 | 7.92 | 9.52 | 3.81 | 16G |
| P0827.050-14G-A2 | M 5 | 2.0 | 2,5-2,7 | 7.92 | 9.52 | 3.81 | 14G |
| P0827.050-12G-A2 | M 5 | 2.5 | 3,0-3,2 | 7.92 | 9.52 | 3.81 | 12G |
| P0827.050-10G-A2 | M 5 | 3.0 | 3,5-3,7 | 7.92 | 9.52 | 3.81 | 10G |
| P0827.050-08G-A2 | M 5 | 4.0 | 4,5-4,7 | 7.92 | 9.52 | 3.81 | 8G |
| P0827.060-22G-A2 | M 6 | 0.8 | 1,3-1,5 | 9.52 | 11.1 | 5.08 | 22G |
| P0827.060-20G-A2 | M 6 | 1.0 | 1,5-1,7 | 9.52 | 11.1 | 5.08 | 20G |
| P0827.060-18G-A2 | M 6 | 1.2 | 1,7-1,9 | 9.52 | 11.1 | 5.08 | 18G |
| P0827.060-16G-A2 | M 6 | 1.5 | 2,0-2,2 | 9.52 | 11.1 | 5.08 | 16G |
| P0827.060-14G-A2 | M 6 | 2.0 | 2,5-2,7 | 9.52 | 11.1 | 5.08 | 14G |
| P0827.060-12G-A2 | M 6 | 2.5 | 3,0-3,2 | 9.52 | 11.1 | 5.08 | 12G |
| P0827.060-10G-A2 | M 6 | 3.0 | 3,5-3,7 | 9.52 | 11.1 | 5.08 | 10G |
| P0827.060-08G-A2 | M 6 | 4.0 | 4,5-4,7 | 9.52 | 11.1 | 5.08 | 8G |
| P0827.080-22G-A2 | M 8 | 0.8 | 1,3-1,5 | 12.7 | 14.27 | 6.35 | 22G |
| P0827.080-20G-A2 | M 8 | 1.0 | 1,5-1,7 | 12.7 | 14.27 | 6.35 | 20G |



| Order No. | d ₁ | Panel thickness | w ₁ | d ₂ | A/F | h ₁ | For gauge |
|------------------|----------------|-----------------|----------------|----------------|-------|----------------|-----------|
| P0827.080-18G-A2 | M 8 | 1.2 | 1,7-1,9 | 12.7 | 14.27 | 6.35 | 18G |
| P0827.080-16G-A2 | M 8 | 1.5 | 2,0-2,2 | 12.7 | 14.27 | 6.35 | 16G |
| P0827.080-14G-A2 | M 8 | 2.0 | 2,5-2,7 | 12.7 | 14.27 | 6.35 | 14G |
| P0827.080-12G-A2 | M 8 | 2.5 | 3,0-3,2 | 12.7 | 14.27 | 6.35 | 12G |
| P0827.080-10G-A2 | M 8 | 3.0 | 3,5-3,7 | 12.7 | 14.27 | 6.35 | 10G |
| P0827.080-08G-A2 | M 8 | 4.0 | 4,5-4,7 | 12.7 | 14.27 | 6.35 | 8G |
| P0827.100-22G-A2 | M10 | 0.8 | 1,3-1,5 | 15.87 | 19.05 | 7.62 | 22G |
| P0827.100-20G-A2 | M10 | 1.0 | 1,5-1,7 | 15.87 | 19.05 | 7.62 | 20G |
| P0827.100-18G-A2 | M10 | 1.2 | 1,7-1,9 | 15.87 | 19.05 | 7.62 | 18G |
| P0827.100-16G-A2 | M10 | 1.5 | 2,0-2,2 | 15.87 | 19.05 | 7.62 | 16G |
| P0827.100-14G-A2 | M10 | 2.0 | 2,5-2,7 | 15.87 | 19.05 | 7.62 | 14G |
| P0827.100-12G-A2 | M10 | 2.5 | 3,0-3,2 | 15.87 | 19.05 | 7.62 | 12G |
| P0827.100-10G-A2 | M10 | 3.0 | 3,5-3,7 | 15.87 | 19.05 | 7.62 | 10G |
| P0827.100-08G-A2 | M10 | 4.0 | 4,5-4,7 | 15.87 | 19.05 | 7.62 | 8G |
| P0827.120-22G-A2 | M12 | 0.8 | 1,3-1,5 | 19.05 | 22.22 | 10.16 | 22G |
| P0827.120-20G-A2 | M12 | 1.0 | 1,5-1,7 | 19.05 | 22.22 | 10.16 | 20G |
| P0827.120-18G-A2 | M12 | 1.2 | 1,7-1,9 | 19.05 | 22.22 | 10.16 | 18G |
| P0827.120-16G-A2 | M12 | 1.5 | 2,0-2,2 | 19.05 | 22.22 | 10.16 | 16G |
| P0827.120-14G-A2 | M12 | 2.0 | 2,5-2,7 | 19.05 | 22.22 | 10.16 | 14G |
| P0827.120-12G-A2 | M12 | 2.5 | 3,0-3,2 | 19.05 | 22.22 | 10.16 | 12G |
| P0827.120-10G-A2 | M12 | 3.0 | 3,5-3,7 | 19.05 | 22.22 | 10.16 | 10G |
| P0827.120-08G-A2 | M12 | 4.0 | 4,5-4,7 | 19.05 | 22.22 | 10.16 | 8G |