

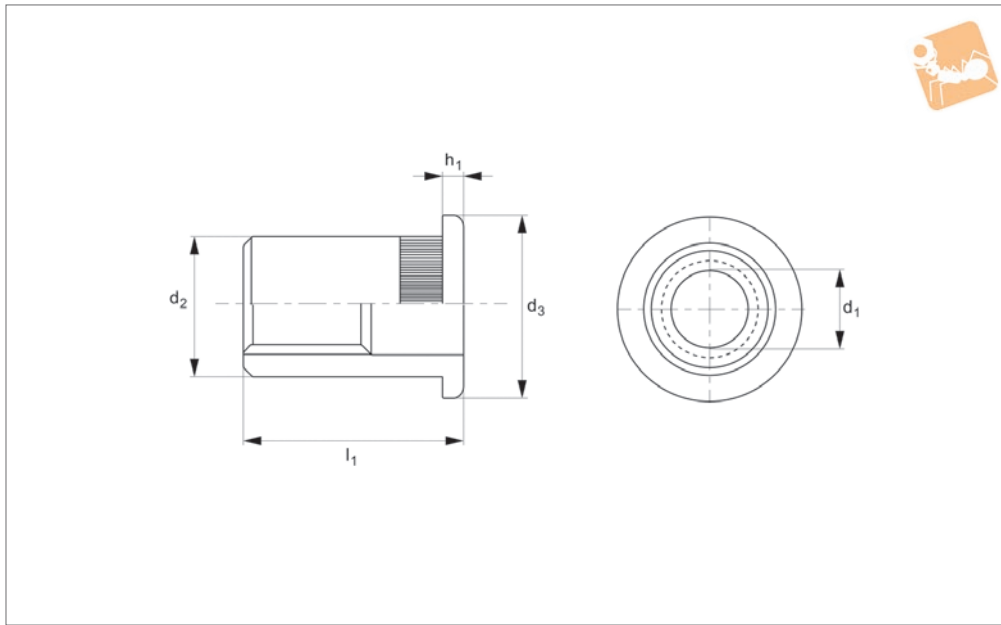

Flange Head Knurled Insert Nuts

Steel, zinc-plated

Insert Nuts



P0820.ZP

INSERT NUTS

Material

Steel, zinc-plated.

Technical Notes

Knurled body type, plain available on request.

Flange head insert nuts are recommended for use in load bearing applications. The larger sized head acts as a reinforcement to the hole and provides resistance to push-out.

The knurled body provides extra turning resistance and the head acts as a spacer.

Tips

Also known as blind rivet nuts or grip nuts.

Order No.	d ₁	Grip range	d ₂ +0 -0.2	d ₃	h ₁	l ₁
P0820.030-025-ZP	M 3	0,5-2,5	4.9	7.0	0.9	10.9
P0820.030-040-ZP	M 3	2,5-4,0	4.9	7.0	0.9	11.5
P0820.040-025-ZP	M 4	0,5-2,5	5.9	9.0	0.9	11.6
P0820.040-055-ZP	M 4	3,0-5,5	5.9	9.0	1.0	14.0
P0820.050-025-ZP	M 5	0,5-2,5	6.9	10.0	1.0	13.0
P0820.060-030-ZP	M 6	0,5-3,0	8.9	12.3	1.3	15.5
P0820.060-055-ZP	M 6	3,0-5,5	8.9	12.3	1.3	19.5
P0820.060-080-ZP	M 6	5,5-8,0	8.9	12.3	1.5	21.0
P0820.080-030-ZP	M 8	0,7-3,0	10.9	16.0	1.5	17.5
P0820.080-055-ZP	M 8	3,0-5,5	10.9	16.0	1.5	20.0
P0820.080-060-ZP	M 8	3,5-6,0	10.9	15.0	1.5	21.0
P0820.080-080-ZP	M 8	5,5-8,0	10.9	15.0	1.6	24.0
P0820.080-105-ZP	M 8	8,0-10,5	10.9	15.0	1.6	25.0
P0820.100-030-ZP	M10	1,0-3,0	11.9	16.0	2.0	19.0
P0820.100-060-ZP	M10	3,0-6,0	11.9	16.0	2.0	24.0
P0820.100-090-ZP	M10	6,0-9,0	11.9	16.0	2.0	27.0
P0820.100-120-ZP	M10	9,0-12,0	11.9	16.0	2.0	30.0
P0820.100-035-ZP	M10	1,0-3,5	12.9	19.0	2.0	21.0
P0820.100-060A-ZP	M10	3,5-6,0	12.9	19.0	2.0	23.5
P0820.120-040-ZP	M12	1,0-4,0	15.9	22.0	2.1	25.0
P0820.120-070-ZP	M12	4,0-7,0	15.9	22.0	2.1	28.0
P0820.120-100-ZP	M12	7,0-10,0	15.9	22.0	2.1	31.0
P0820.050-055-ZP	M 5	3,0-5,5	6.9	10.0	1.0	16.0
P0820.050-080-ZP	M 5	5,5-8,0	6.9	10.0	1.0	19.0