

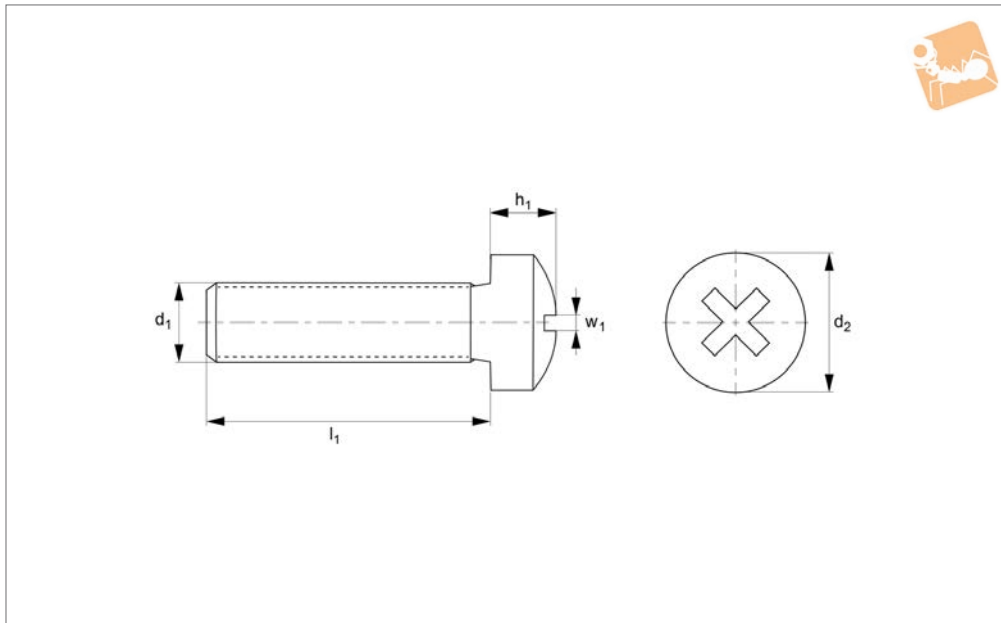

Phillips Pan Head Screws

Phillips - steel, zinc-plated

Standard Screws



P0234.ZP

STANDARD SCREWS

Material

Steel, zinc-plated (grade 4.8).

Technical Notes

To DIN 7985 H, ISO 7045. Threaded within 2,5 x pitch of head.

Order No.	d ₁	l ₁	d ₂	h ₁	Size
P0234.016-003-ZP	M1,6	3	3.2	1.3	PH-0
P0234.016-004-ZP	M1,6	4	3.2	1.3	PH-0
P0234.016-005-ZP	M1,6	5	3.2	1.3	PH-0
P0234.016-006-ZP	M1,6	6	3.2	1.3	PH-0
P0234.016-008-ZP	M1,6	8	3.2	1.3	PH-0
P0234.016-010-ZP	M1,6	10	3.2	1.3	PH-0
P0234.016-012-ZP	M1,6	12	3.2	1.3	PH-0
P0234.016-014-ZP	M1,6	14	3.2	1.3	PH-0
P0234.016-016-ZP	M1,6	16	3.2	1.3	PH-0
P0234.016-018-ZP	M1,6	18	3.2	1.3	PH-0
P0234.020-003-ZP	M 2	3	4	1.6	PH-1
P0234.020-004-ZP	M 2	4	4	1.6	PH-1
P0234.020-005-ZP	M 2	5	4	1.6	PH-1
P0234.020-006-ZP	M 2	6	4	1.6	PH-1
P0234.020-008-ZP	M 2	8	4	1.6	PH-1
P0234.020-010-ZP	M 2	10	4	1.6	PH-1
P0234.020-012-ZP	M 2	12	4	1.6	PH-1
P0234.020-014-ZP	M 2	14	4	1.6	PH-1
P0234.020-016-ZP	M 2	16	4	1.6	PH-1
P0234.020-018-ZP	M 2	18	4	1.6	PH-1
P0234.020-020-ZP	M 2	20	4	1.6	PH-1
P0234.025-003-ZP	M2,5	3	5	2.0	PH-1
P0234.025-004-ZP	M2,5	4	5	2.0	PH-1
P0234.025-005-ZP	M2,5	5	5	2.0	PH-1
P0234.025-006-ZP	M2,5	6	5	2.0	PH-1
P0234.025-008-ZP	M2,5	8	5	2.0	PH-1
P0234.025-010-ZP	M2,5	10	5	2.0	PH-1
P0234.025-012-ZP	M2,5	12	5	2.0	PH-1
P0234.025-016-ZP	M2,5	16	5	2.0	PH-1
P0234.025-020-ZP	M2,5	20	5	2.0	PH-1
P0234.025-025-ZP	M2,5	25	5	2.0	PH-1
P0234.030-004-ZP	M 3	4	6	2.4	PH-1
P0234.030-005-ZP	M 3	5	6	2.4	PH-1
P0234.030-006-ZP	M 3	6	6	2.4	PH-1
P0234.030-008-ZP	M 3	8	6	2.4	PH-1



STANDARD SCREWS

Order No.	d ₁	l ₁	d ₂	h ₁	Size
P0234.030-010-ZP	M 3	10	6	2.4	PH-1
P0234.030-012-ZP	M 3	12	6	2.4	PH-1
P0234.030-014-ZP	M 3	14	6	2.4	PH-1
P0234.030-016-ZP	M 3	16	6	2.4	PH-1
P0234.030-018-ZP	M 3	18	6	2.4	PH-1
P0234.030-020-ZP	M 3	20	6	2.4	PH-1
P0234.030-022-ZP	M 3	22	6	2.4	PH-1
P0234.030-025-ZP	M 3	25	6	2.4	PH-1
P0234.030-028-ZP	M 3	28	6	2.4	PH-1
P0234.030-030-ZP	M 3	30	6	2.4	PH-1
P0234.030-035-ZP	M 3	35	6	2.4	PH-1
P0234.030-040-ZP	M 3	40	6	2.4	PH-1
P0234.040-004-ZP	M 4	4	6	3.1	PH-2
P0234.040-005-ZP	M 4	5	6	3.1	PH-2
P0234.040-006-ZP	M 4	6	6	3.1	PH-2
P0234.040-008-ZP	M 4	8	6	3.1	PH-2
P0234.040-010-ZP	M 4	10	6	3.1	PH-2
P0234.040-012-ZP	M 4	12	6	3.1	PH-2
P0234.040-014-ZP	M 4	14	6	3.1	PH-2
P0234.040-016-ZP	M 4	16	6	3.1	PH-2
P0234.040-018-ZP	M 4	18	6	3.1	PH-2
P0234.040-020-ZP	M 4	20	6	3.1	PH-2
P0234.040-022-ZP	M 4	22	6	3.1	PH-2
P0234.040-025-ZP	M 4	25	6	3.1	PH-2
P0234.040-028-ZP	M 4	28	6	3.1	PH-2
P0234.040-030-ZP	M 4	30	6	3.1	PH-2
P0234.040-035-ZP	M 4	35	6	3.1	PH-2
P0234.040-040-ZP	M 4	40	6	3.1	PH-2
P0234.040-045-ZP	M 4	45	6	3.1	PH-2
P0234.040-050-ZP	M 4	50	6	3.1	PH-2
P0234.040-055-ZP	M 4	55	6	3.1	PH-2
P0234.040-060-ZP	M 4	60	6	3.1	PH-2
P0234.040-065-ZP	M 4	65	6	3.1	PH-2
P0234.040-070-ZP	M 4	70	6	3.1	PH-2
P0234.040-080-ZP	M 4	80	6	3.1	PH-2
P0234.040-090-ZP	M 4	90	6	3.1	PH-2
P0234.040-100-ZP	M 4	100	6	3.1	PH-2
P0234.050-006-ZP	M 5	6	6	3.8	PH-2
P0234.050-008-ZP	M 5	8	6	3.8	PH-2
P0234.050-010-ZP	M 5	10	6	3.8	PH-2
P0234.050-012-ZP	M 5	12	6	3.8	PH-2
P0234.050-014-ZP	M 5	14	6	3.8	PH-2
P0234.050-016-ZP	M 5	16	6	3.8	PH-2
P0234.050-018-ZP	M 5	18	6	3.8	PH-2
P0234.050-020-ZP	M 5	20	6	3.8	PH-2
P0234.050-022-ZP	M 5	22	6	3.8	PH-2
P0234.050-025-ZP	M 5	25	6	3.8	PH-2
P0234.050-028-ZP	M 5	28	6	3.8	PH-2
P0234.050-030-ZP	M 5	30	6	3.8	PH-2
P0234.050-035-ZP	M 5	35	6	3.8	PH-2
P0234.050-040-ZP	M 5	40	6	3.8	PH-2
P0234.050-045-ZP	M 5	45	6	3.8	PH-2
P0234.050-050-ZP	M 5	50	6	3.8	PH-2
P0234.050-055-ZP	M 5	55	6	3.8	PH-2
P0234.050-060-ZP	M 5	60	6	3.8	PH-2
P0234.050-065-ZP	M 5	65	6	3.8	PH-2
P0234.050-070-ZP	M 5	70	6	3.8	PH-2
P0234.050-080-ZP	M 5	80	6	3.8	PH-2
P0234.050-090-ZP	M 5	90	6	3.8	PH-2
P0234.050-100-ZP	M 5	100	6	3.8	PH-2
P0234.060-008-ZP	M 6	8	6	4.6	PH-3
P0234.060-010-ZP	M 6	10	6	4.6	PH-3
P0234.060-012-ZP	M 6	12	6	4.6	PH-3
P0234.060-014-ZP	M 6	14	6	4.6	PH-3
P0234.060-016-ZP	M 6	16	6	4.6	PH-3
P0234.060-018-ZP	M 6	18	6	4.6	PH-3
P0234.060-020-ZP	M 6	20	6	4.6	PH-3
P0234.060-022-ZP	M 6	22	6	4.6	PH-3
P0234.060-025-ZP	M 6	25	6	4.6	PH-3



Phillips Pan Head Screws

Phillips - steel, zinc-plated

Standard Screws



Order No.	d ₁	l ₁	d ₂	h ₁	Size
P0234.060-028-ZP	M 6	28	6	4.6	PH-3
P0234.060-030-ZP	M 6	30	6	4.6	PH-3
P0234.060-035-ZP	M 6	35	6	4.6	PH-3
P0234.060-040-ZP	M 6	40	6	4.6	PH-3
P0234.060-045-ZP	M 6	45	6	4.6	PH-3
P0234.060-050-ZP	M 6	50	6	4.6	PH-3
P0234.060-055-ZP	M 6	55	6	4.6	PH-3
P0234.060-060-ZP	M 6	60	6	4.6	PH-3
P0234.060-065-ZP	M 6	65	6	4.6	PH-3
P0234.060-070-ZP	M 6	70	6	4.6	PH-3
P0234.060-080-ZP	M 6	80	6	4.6	PH-3
P0234.060-090-ZP	M 6	90	6	4.6	PH-3
P0234.060-100-ZP	M 6	100	6	4.6	PH-3
P0234.080-010-ZP	M 8	10	6	6.0	PH-4
P0234.080-012-ZP	M 8	12	6	6.0	PH-4
P0234.080-014-ZP	M 8	14	6	6.0	PH-4
P0234.080-016-ZP	M 8	16	6	6.0	PH-4
P0234.080-018-ZP	M 8	18	6	6.0	PH-4
P0234.080-020-ZP	M 8	20	6	6.0	PH-4
P0234.080-022-ZP	M 8	22	6	6.0	PH-4
P0234.080-025-ZP	M 8	25	6	6.0	PH-4
P0234.080-028-ZP	M 8	28	6	6.0	PH-4
P0234.080-030-ZP	M 8	30	6	6.0	PH-4
P0234.080-035-ZP	M 8	35	6	6.0	PH-4
P0234.080-040-ZP	M 8	40	6	6.0	PH-4
P0234.080-045-ZP	M 8	45	6	6.0	PH-4
P0234.080-050-ZP	M 8	50	6	6.0	PH-4
P0234.080-055-ZP	M 8	55	6	6.0	PH-4
P0234.080-060-ZP	M 8	60	6	6.0	PH-4
P0234.080-065-ZP	M 8	65	6	6.0	PH-4
P0234.080-070-ZP	M 8	70	6	6.0	PH-4
P0234.080-080-ZP	M 8	80	6	6.0	PH-4
P0234.080-090-ZP	M 8	90	6	6.0	PH-4
P0234.080-100-ZP	M 8	100	6	6.0	PH-4

STANDARD SCREWS