

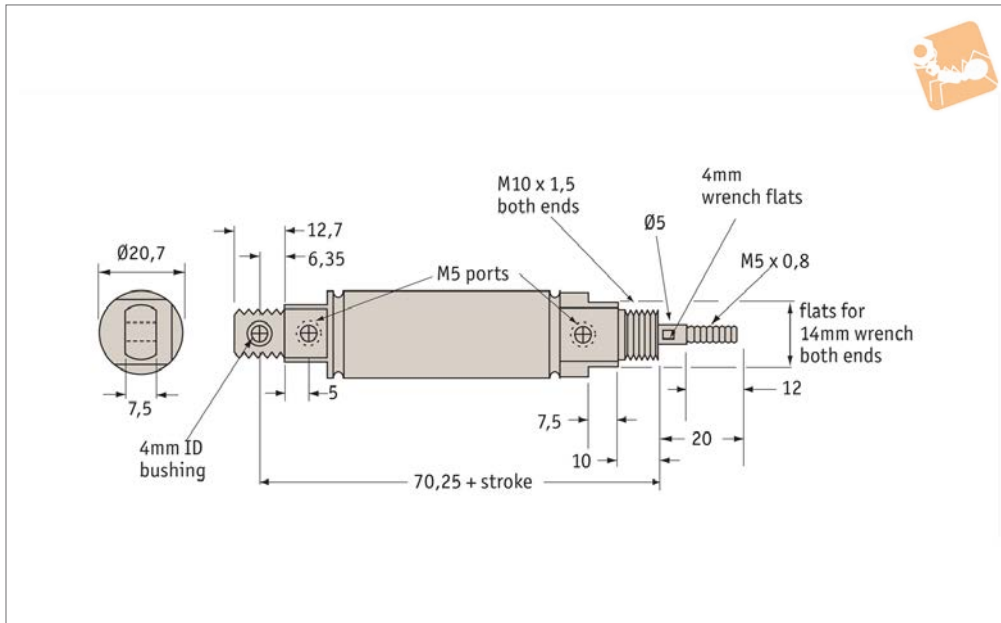

Anti-Stiction Air Cylinder - universal mount

Cylinders



L4520

CYLINDERS

Material

Carbon/graphite piston. Stainless steel rod (AISI 303). Stainless Steel outer tube (AISI 304). Nickel plated aluminium cylinder heads and piston/rod coupling. Graphite filled bronze pivot bushing.

Technical Notes

Ultra low friction.
Corrosion resistant, no need for lubrication.

Operating temp range: -55°C to +150°C.
For applications operating below -20°C please add -ET to part number. Suitable for vacuum actuation.
Piston area = 198mm².
Force output at max pressure on rear side = 139N.
Force output at max pressure on rod side = 125N.
Piston friction as % of load (without side

load) = 1% - 2%.
Min pressure differential required for actuation = <0.0015 MPa.
Force factor rear side = 198N.
Force factor rod side = 178N.
(factor x pressure (MPa) = force output (N)).
*max leak measured at pressure of 0.34 MPa.

Order No.	Bore dia.	Stroke	Length	Pressure MPa max.	Leak rate by piston max. SL/min	Leak rate by rod max. SL/min	Weight g
L4520.012	15.9	12.5	82.75	0.7	1.39	2.6	72.38
L4520.025	15.9	25.0	95.25	0.7	1.39	2.6	80.15
L4520.037	15.9	37.5	107.75	0.7	1.39	2.6	87.93
L4520.050	15.9	50.0	120.25	0.7	1.39	2.6	95.70
L4520.075	15.9	75.0	145.25	0.7	1.39	2.6	111.25
L4520.100	15.9	100.0	170.25	0.7	1.39	2.6	126.80
L4520.125	15.9	125.0	195.25	0.7	1.39	2.6	142.35
L4520.150	15.9	150.0	220.50	0.7	1.39	2.6	157.90
L4520.175	15.9	175.0	245.25	0.7	1.39	2.6	173.45
L4520.200	15.9	200.0	270.25	0.7	1.39	2.6	189.00
L4520.225	15.9	225.0	295.25	0.7	1.39	2.6	204.55
L4520.250	15.9	250.0	320.25	0.7	1.39	2.6	220.10
L4520.275	15.9	275.0	345.25	0.7	1.39	2.6	235.65
L4520.300	15.9	300.0	370.25	0.7	1.39	2.6	251.20