

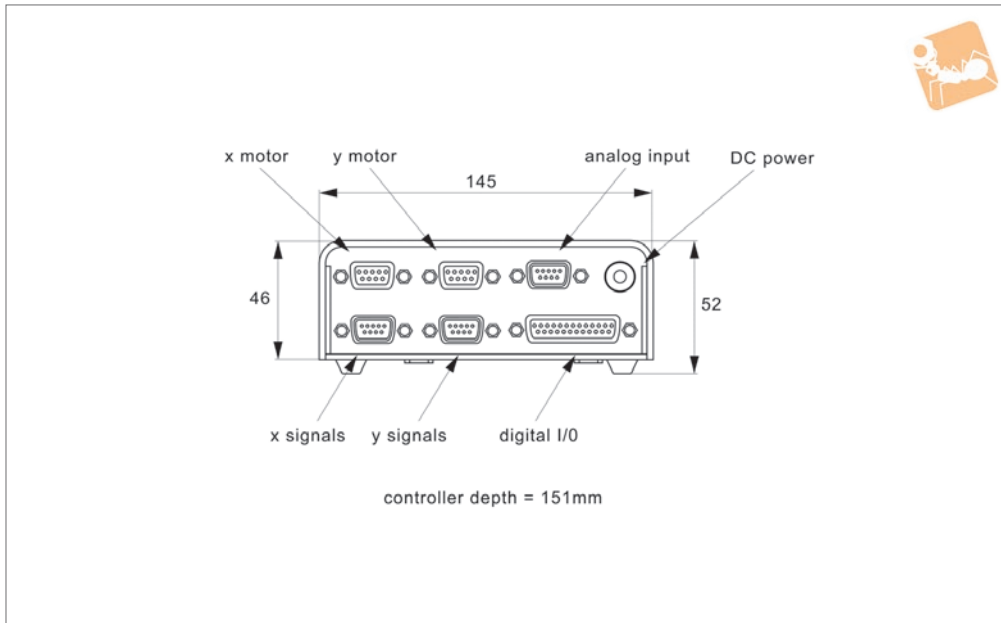

Two Axes Stepper Controllers

Motorised Linear Stages

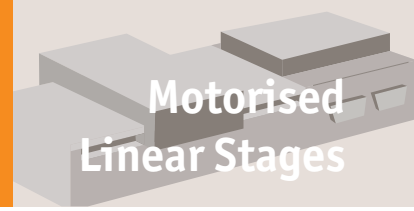

L3522

MOTORISED LINEAR STAGES

Material

Includes universal AC power adapter, user interface software and USB cable.

Technical Notes

Communication: USB 2,0 or RS-485 ASCII (9600 - 115200 bps)

Digital IO Communication: 4 bit motion profile select inputs (DI3-DI6). One start motion input (DI1). One abort/clear motion input (DI2). One in position output (DO1). One error output (DO2).

A/B/Z differential encoder inputs (Max frequency of 5 MHz): StepNLoop closed loop control (position verification)

2 x 10-bit analog inputs.

Opto-isolated I/O: 8 x inputs, 8 x outputs, +Limit/-Limit/Home inputs per axis
Stand alone programmable.
Max. pulse input rate of 400K.

Tips

Can be plugged into, and control two axis simultaneously. Comes with cables and software. Simple plug and play system via USB port of your laptop or PC.
This motion controller can only be used with stages that have a stepper motor attached. If you have a Servo motor, see part number L3297.

Micro-stepping is the number of steps per step of the motor output shaft. e.g the stepper motors have 200 steps per revolution of the shaft. If the motion controllers are set to 8 microsteps, this means that the motor shaft has 1600 steps per revolution (8 x 200).

Compatible with LabView, Matlab, VB, C++, Python, and OS X.

Important Notes

When using with Matlab a RS-485 to USB adapter will be required.

Order No.	No. of axes	Encoder	Input voltage V DC	Output current Amps max.	Micro-step resolution	Weight kg
L3522.ST2X	Two	No	+12 to +24	1.5	1 to 8	0.45
L3522.ST2X-E	Two	Yes	+12 to +24	1.5	1 to 8	0.45
L3522.RS485	USB cable	-	-	-	-	-

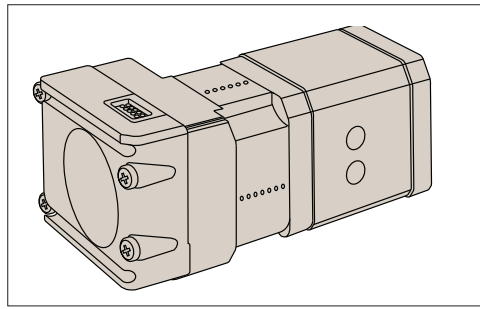

Intelligent stepper motor

- No need for separate motion controller.
- Inbuilt motor, driver and controller.

Options

- Standard
- With rotary encoder (512 line)

Separate motor controllers (single axis)

Single axis stepper controller



Single axis servo controller



Intelligent stepper motor

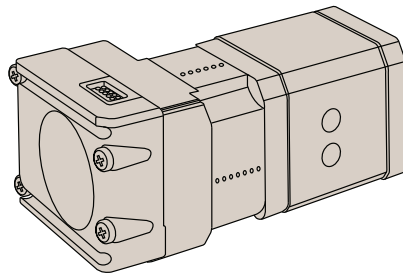

- Standard
- With rotary encoder (512 line)

Stepper motor

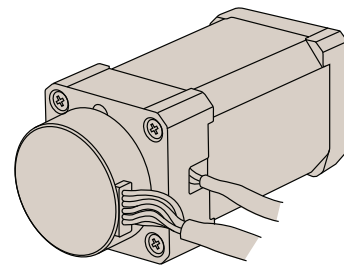

- Standard
- With rotary encoder (1000 line)

Servo motor

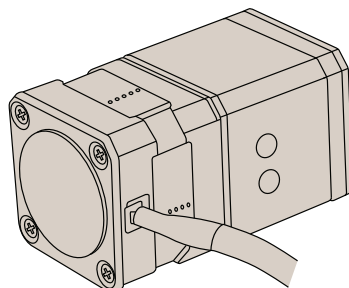

- Standard
- With rotary encoder (1000 line)

Positioning Stages from Automation Components

MOTORISED LINEAR STAGES

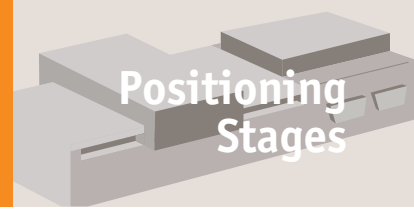

Controllers



L3294 Single axis stepper motor controller

- Communicate via RS-232 or Ethernet interface
- Uses virtually any programming language



L3295 Two axis stepper motor controller

- Communicate via RS-232 or Ethernet interface
- Programming via Labupu, VB, C++ and OSX etc.
- Stand alone programs can be downloaded
- Max output of 1.5A



L3296 Multi axis stepper motor controller

- Communicate via RS-232 or Ethernet interface
- Can control 4 axis and perform coordinated or independent motion of each or all the axis simultaneously
- Uses virtually any programming language



L3297 Single axis servo motor controller

- Communicate via RS-232 or Ethernet interface
- Uses virtually any programming language

Accessories



Joysticks



Digital readout



Connector RS232-USB

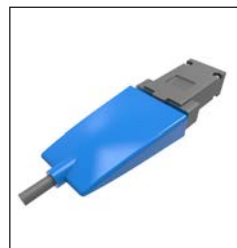

Connector RS422-USB

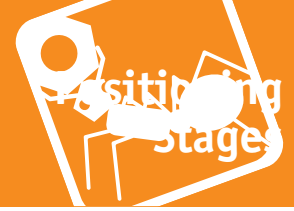

These have major benefits as they combine the motor (from size NEMA17 up) with an inbuilt driver and controller.

- Stepper or servo motor versions.
- Simple to install
- CE certified
- Free software programming

Plug and play

- Download free software
- Connect motor to computer (USB port)
- Connect power supply to the motor
- Start controlling/programming

- Low cost solution.
- The I/O points can be set by users to input, output or analogue input.
- NEMA17, 23, 34, 43 and larger sizes available.
- 12-48VDC.
- High torque stepper motors (1.2 to 10.5 Nm).
- Simple Windows software program provided free).
- Also Labview VB etc. programs.
- IP67, Motor brake.
- Optional Joysticks.