

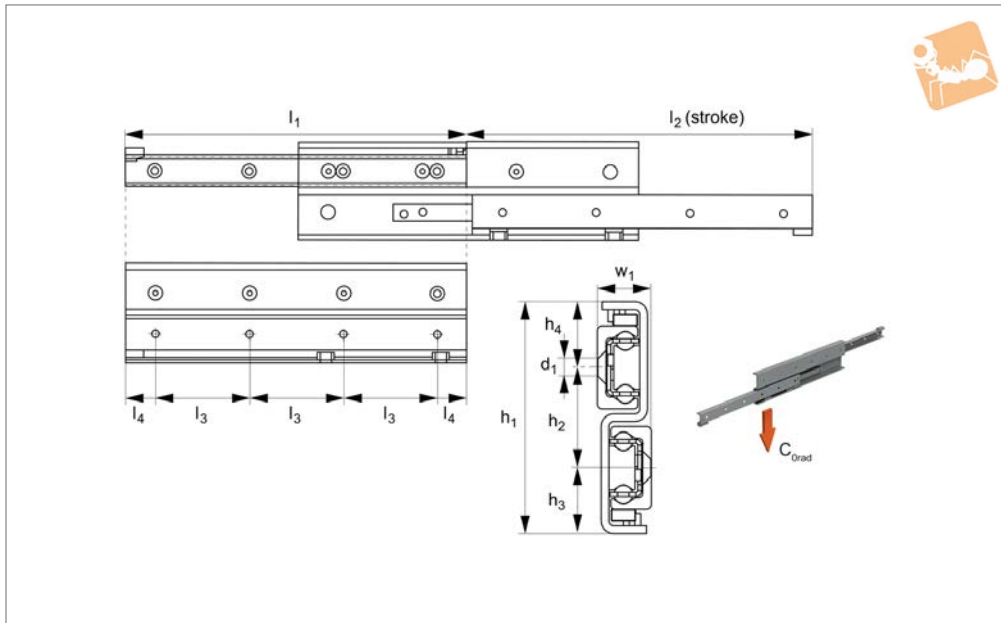

Fully Telescopic Slides, size 35

single direction stroke

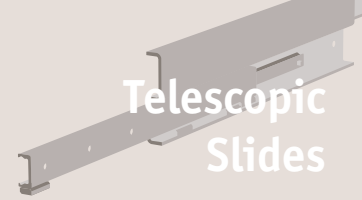

L1984.35S

TELESCOPIC SLIDES

Material

Cold drawn bearing steel raceways hardened to 60 HRC. Balls - hardened steel.
Zinc coating to ISO2081 (excluding raceways). Corrosion resistant coatings available on request.

Technical Notes

These are extremely strong and rigid teles-

copic slides with high load capacities and have very low deflection characteristics. Temperature range: -30°C to +110°C. This is the single direction stroke version - the moving member can extend out of only one side of the slide. Moving rail must be lower rail (unless technical department consulted). C_{0rad} is the load rating for a single teles-

copic slide.

Tips

The slides have end stops, but these are not designed to stop a moving, loaded slide. External end stops should be used for this. Special strokes up to 130% of the closed length can be provided on request. Only to be used for horizontal movements.

Order No.	h_1	h_2	h_3	h_4	l_1	l_2 stroke	l_3	l_4	w_1	For screws d_1	Accessible holes/total	Load (per rail) C_{0rad} N max.	Weight kg
L1984.35S-0450	104	43	30,5	30,5	450	494	80	25	22,5	M6	5/6	1250	4,5
L1984.35S-0530	104	43	30,5	30,5	530	558	80	25	22,5	M6	6/7	1685	5,4
L1984.35S-0610	104	43	30,5	30,5	610	646	80	25	22,5	M6	6/8	1908	6,2
L1984.35S-0690	104	43	30,5	30,5	690	734	80	25	22,5	M6	7/9	2132	9,9
L1984.35S-0770	104	43	30,5	30,5	770	798	80	25	22,5	M6	8/10	2579	7,7
L1984.35S-0850	104	43	30,5	30,5	850	886	80	25	22,5	M6	9/11	2801	8,9
L1984.35S-0930	104	43	30,5	30,5	930	974	80	25	22,5	M6	9/12	3024	9,4
L1984.35S-1010	104	43	30,5	30,5	1010	1038	80	25	22,5	M6	10/13	3476	10,2
L1984.35S-1090	104	43	30,5	30,5	1090	1126	80	25	22,5	M6	11/14	3508	11,0
L1984.35S-1170	104	43	30,5	30,5	1170	1214	80	25	22,5	M6	12/15	3240	11,8
L1984.35S-1250	104	43	30,5	30,5	1250	1278	80	25	22,5	M6	12/16	3121	12,6
L1984.35S-1330	104	43	30,5	30,5	1330	1366	80	25	22,5	M6	13/17	2907	13,4
L1984.35S-1410	104	43	30,5	30,5	1410	1454	80	25	22,5	M6	14/18	2721	14,2
L1984.35S-1490	104	43	30,5	30,5	1490	1518	80	25	22,5	M6	15/19	2636	15,0
L1984.35S-1570	104	43	30,5	30,5	1570	1606	80	25	22,5	M6	15/20	2482	15,9
L1984.35S-1650	104	43	30,5	30,5	1650	1694	80	25	22,5	M6	16/21	2345	16,6
L1984.35S-1730	104	43	30,5	30,5	1730	1758	80	30,5	22,5	M6	17/22	2282	17,5



If you are looking for heavy duty, quality telescopic rails for industrial or commercial applications then these are the rails for you!

The best heavy duty telescopic slides on the market

These are unique rails that are not made from pressed steel but from cold-drawn steel section. The rails can take high loads, with very long strokes, with repeated use, low deflection and minimal play.

TELESCOPIC SLIDES

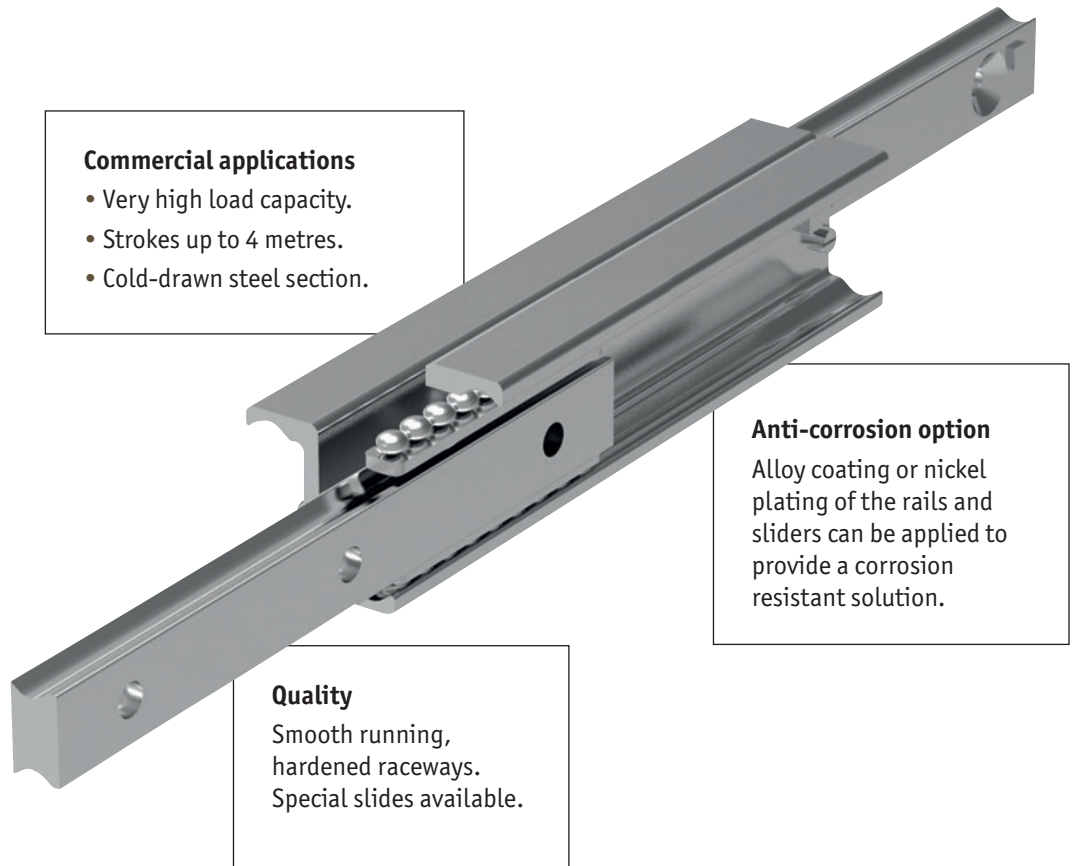

Commercial applications

- Very high load capacity.
- Strokes up to 4 metres.
- Cold-drawn steel section.

Anti-corrosion option

Alloy coating or nickel plating of the rails and sliders can be applied to provide a corrosion resistant solution.

Quality

Smooth running, hardened raceways. Special slides available.

Rail types

Our range of telescopic rails covers partial, full stroke and over-extension.

For more information refer to our product specifications pages or call our technical department.

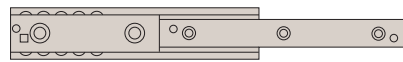

Partial Stroke (~60%)

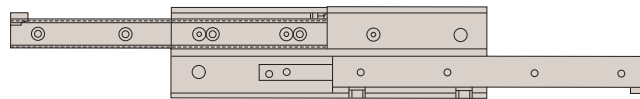

Full Stroke (~100%)

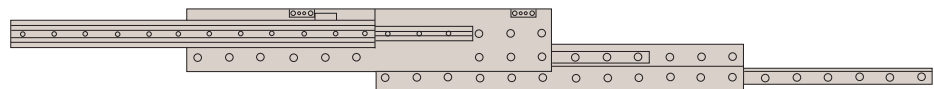

Over-extension (150%)



Telescopic Rail

Specifications and applications

Telescopic Rail

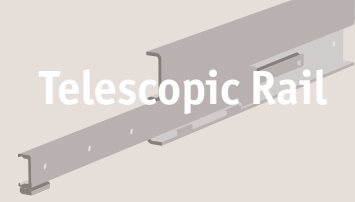

Specifications

- Generally all our telescopic rails have induction hardened raceways.
- Cold drawn roller bearing steel.
- Maximum operating speed 0,8 m/s.
- Temperature range (mainly -30°C to +170°C).
- Electrolytic galvanised to ISO 2081, other anti-corrosion finishes on request.
- High load ratings with low deflection characteristics.
- Minimum play (even at maximum load ratings).
- Smooth, free running movement.
- Long strokes and heavy load ratings.
- Can be used in horizontal applications only (due to the use of a ball cage), with the exception of part number L1985 which uses roller bearings.
- Light duty “cage stops” are included on the telescopic rails to prevent damage to the ball cage. External end stops must be designed into your application (to protect the rails from high forces and possible damage on opening and closing).
- For telescopic rails with an “upper” and “lower” rail, the moving rail should be the lower one. Using the upper rail as the moving element effects the smooth running and the load capacity of the telescopic sliders.
- All load capacity figures are given for a single rail, and based on continuous use.
- Fix to structures using screws of strength class 10,9.
- Anti-corrosion option. We have a highly effective anti-corrosive coating option, and we utilise stainless steel ball bearings in this version.

Applications



Special purpose & packaging machines

Precision positioning systems
handling units
robotic systems • cutting machines



Seating

Sliding seats
disability ramps
seat extensions



Safety guarding

Extending protective systems
sliding gates
automatic pick & place



Logistics solutions

Container extensions
heavy duty extending systems
sliding doors



Disability vehicles

Sliding seats
extension ramps



Transport (naval)

Sliding hatches
pull-out storage



Transport (rail)

Seat adjustment
sliding doors
battery removal units



Transport (automotive)

Ambulance sliding systems
fire fighting vehicles
sliding panels



Transport (military)

Sliding seats
protective hatches
stretcher extensions



Partial extension telescopic slides

L1994 - these are extremely compact rails with a simple design and very high load ratings. They have high radial and axial load capacity as well as the ability to take considerable moment loads.

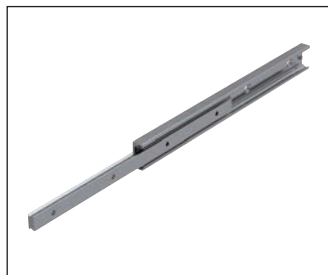

Standard extension	50%
Special extension range	up to 65% (on request)
Single & double direction?	Yes (remove end stop)
Number of rail sizes	5
Maximum extension (at 50%)	1010 mm
Maximum load (per rail)	4500 Kg

Full extension telescopic slides

L1984 - these are very thin rails with high levels of rigidity and load capacity. Very low deflection even when fully loaded and in an open position.

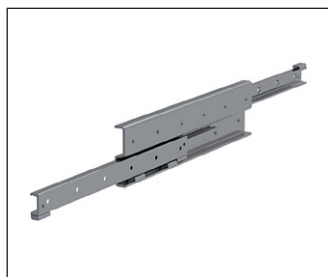

Standard extension	100%
Special extension range	up to 130% (on request)
Single & double direction?	Yes (specify on ordering)
Number of rail sizes	4
Maximum extension (at 100%)	2020 mm
Maximum load (per rail)	1200 Kg

L1986 - a very low height rail gives the slide very rigid capabilities. The double T cross section allows a compact size with low radial loading deflection and axial load capability too.

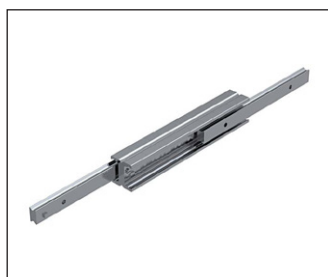

Standard extension	100%
Special extension range	up to 130% (on request)
Single & double direction?	Yes (remove end stop)
Number of rail sizes	5
Maximum extension (at 100%)	2020 mm
Maximum load (per rail)	700 Kg

L1988 - the compact, low profile, square shaped configuration gives the slides similar load capacities for radial and axial loads.



Standard extension	100%
Special extension range	up to 130% (on request)
Single & double direction?	Yes (remove end stop)
Number of rail sizes	4
Maximum extension (at 100%)	2020 mm
Maximum load (per rail)	1250 Kg

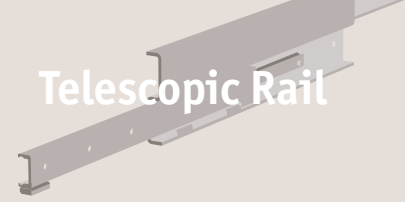

Speed

The maximum operating speed is determined by the mass of the intermediate element, which moves with the movable rail. This reduces the maximum permissible operating speed with the increasing length.

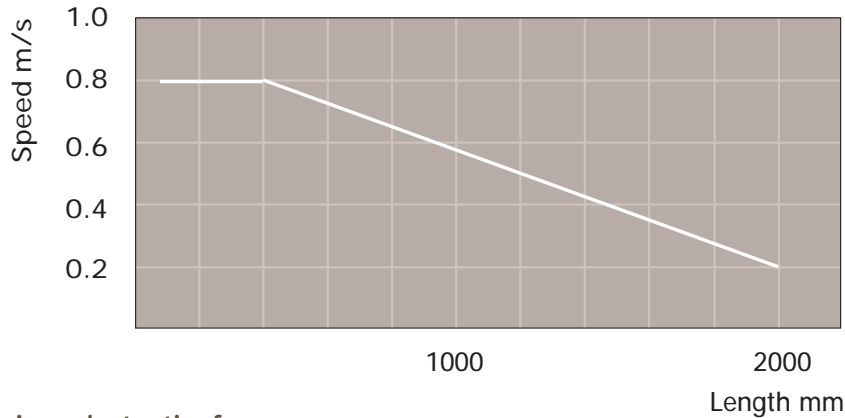

Extension and extraction force

The required actuation forces of a telescopic rail depend on the acting load and the deflection in the extended state. The force required for opening is principally determined by the coefficient of friction of the linear bearing, with correct assembly and lubrication, this is 0,01.

During the extension, the force is reduced with the elastic deflection of the loaded telescopic rail. A higher force is required to close a telescopic extension, since, based on the elastic deflection, even if it is minimal, the moveable rail must move against an inclined plane.

Double-sided stroke

For all designs allowing double-sided stroke, it must be carefully noted that the position of the intermediate element is defined only in the extended state.

In the extracted state, the intermediate element may protrude by half of its length on each side (with the exception of both the L1994 series, (which comes out as a partial extension without the intermediate element) and the custom design of series L1986 which can be supplied with special driving disc on request.

The double-sided stroke in series L1994, L1986 and L1988 is achieved by removing the set screw.

For series L1984 version D, the double-sided stroke is achieved with a special set-up so that two types of rails are shown in the catalogue L1986 (single extension) and L1986 (double extension).

The double-sided stroke for series DMS is available on request. Series L1984.DSB (locking version), L1985 and L1992 are not available with double-sided stroke.

Temperature range

- Series L1994, L1986, L1988 and L1992 can be used up to an ambient temperature of +170°C. A lithium lubricant for high operating temperature is recommended for temperatures above 130°C.
- Series L1984 and L1985 have a useable range of -30°C to +110°C due to the rubber stop.