

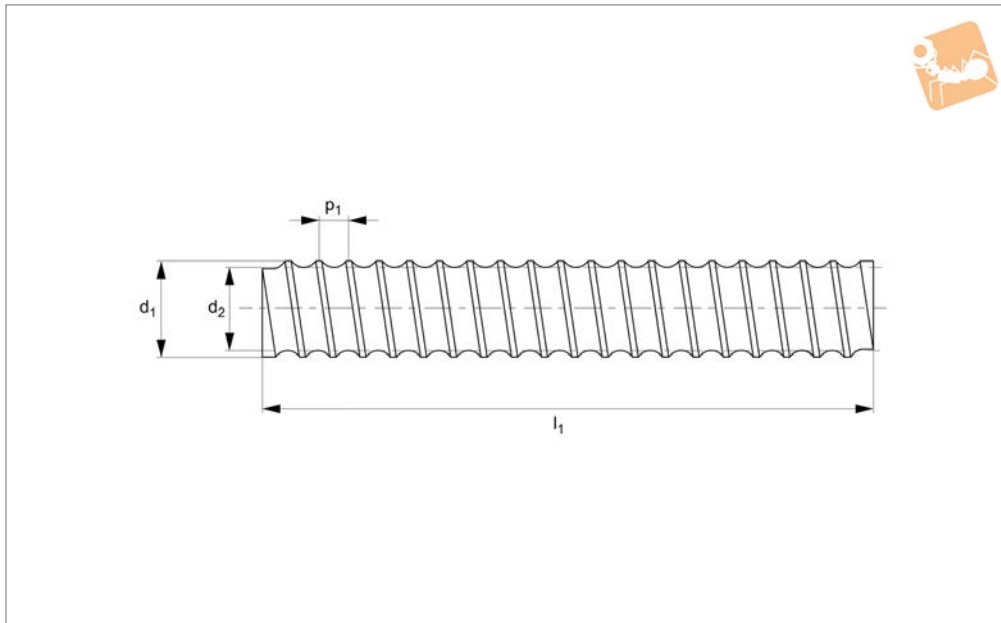

Ø12 Miniature Rolled Ball Screws

Ball Screw & Nuts

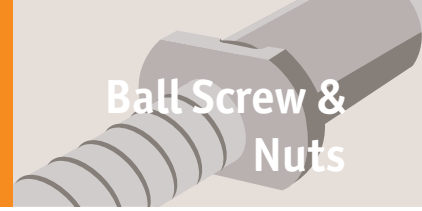

L1379.12

BALL SCREW & NUTS

Material

Steel (Cf53 or C55R), hardened, rust proof chrome plated (X90CrMoV5).

Technical Notes

Tolerance T7 - 50µ/300mm.

For ball screw nuts see parts L1379.F and L1379.C.

For end machining of ball screws to suit miniature or standard ball screw support units please see technical pages.

We provide a service to cut and machine ball screws as required.

Chrome plating for use in food industry etc. contains 98% pure chromium.

Tips

Do not remove the ball nut from the sleeve that it comes with prior to installation - the balls come free rendering the ball nut unusable. Offer up the ball nut still on its mounting sleeve to the ball screw and screw carefully on.

Order No.	d ₁	d ₂ core dia.	l ₁	Lead w ₁	Mass moment of inertia kg·m ²	Screw dia. x lead	Weight kg
L1379.12-20-0100	12	11.21	100	2	1,07x10 ⁻⁵	12x2	0.06
L1379.12-20-0200	12	11.21	200	2	1,07x10 ⁻⁵	12x2	0.12
L1379.12-20-0300	12	11.21	300	2	1,07x10 ⁻⁵	12x2	0.19
L1379.12-20-0400	12	11.21	400	2	1,07x10 ⁻⁵	12x2	0.25
L1379.12-20-0500	12	11.21	500	2	1,07x10 ⁻⁵	12x2	0.31
L1379.12-20-0600	12	11.21	600	2	1,07x10 ⁻⁵	12x2	0.37
L1379.12-20-0700	12	11.21	700	2	1,07x10 ⁻⁵	12x2	0.43
L1379.12-20-0800	12	11.21	800	2	1,07x10 ⁻⁵	12x2	0.50
L1379.12-20-0900	12	11.21	900	2	1,07x10 ⁻⁵	12x2	0.56
L1379.12-20-1000	12	11.21	1000	2	1,07x10 ⁻⁵	12x2	0.62
L1379.12-40-0100	12	9.80	100	4	1,51x10 ⁻⁵	12x4	0.09
L1379.12-40-0200	12	9.80	200	4	1,51x10 ⁻⁵	12x4	0.17
L1379.12-40-0300	12	9.80	300	4	1,51x10 ⁻⁵	12x4	0.26
L1379.12-40-0400	12	9.80	400	4	1,51x10 ⁻⁵	12x4	0.35
L1379.12-40-0500	12	9.80	500	4	1,51x10 ⁻⁵	12x4	0.43
L1379.12-40-0600	12	9.80	600	4	1,51x10 ⁻⁵	12x4	0.52
L1379.12-40-0700	12	9.80	700	4	1,51x10 ⁻⁵	12x4	0.61
L1379.12-40-0800	12	9.80	800	4	1,51x10 ⁻⁵	12x4	0.69
L1379.12-40-0900	12	9.80	900	4	1,51x10 ⁻⁵	12x4	0.77
L1379.12-40-1000	12	9.80	1000	4	1,51x10 ⁻⁵	12x4	0.86
L1379.12-50-0100	12	9.80	100	5	7,64x10 ⁻⁶	12x5	0.09
L1379.12-50-0200	12	9.80	200	5	7,64x10 ⁻⁶	12x5	0.16
L1379.12-50-0300	12	9.80	300	5	7,64x10 ⁻⁶	12x5	0.23
L1379.12-50-0400	12	9.80	400	5	7,64x10 ⁻⁶	12x5	0.31
L1379.12-50-0500	12	9.80	500	5	7,64x10 ⁻⁶	12x5	0.39
L1379.12-50-0600	12	9.80	600	5	7,64x10 ⁻⁶	12x5	0.47
L1379.12-50-0700	12	9.80	700	5	7,64x10 ⁻⁶	12x5	0.55
L1379.12-50-0800	12	9.80	800	5	7,64x10 ⁻⁶	12x5	0.62
L1379.12-50-0900	12	9.80	900	5	7,64x10 ⁻⁶	12x5	0.70
L1379.12-50-1000	12	9.80	1000	5	7,64x10 ⁻⁶	12x5	0.78

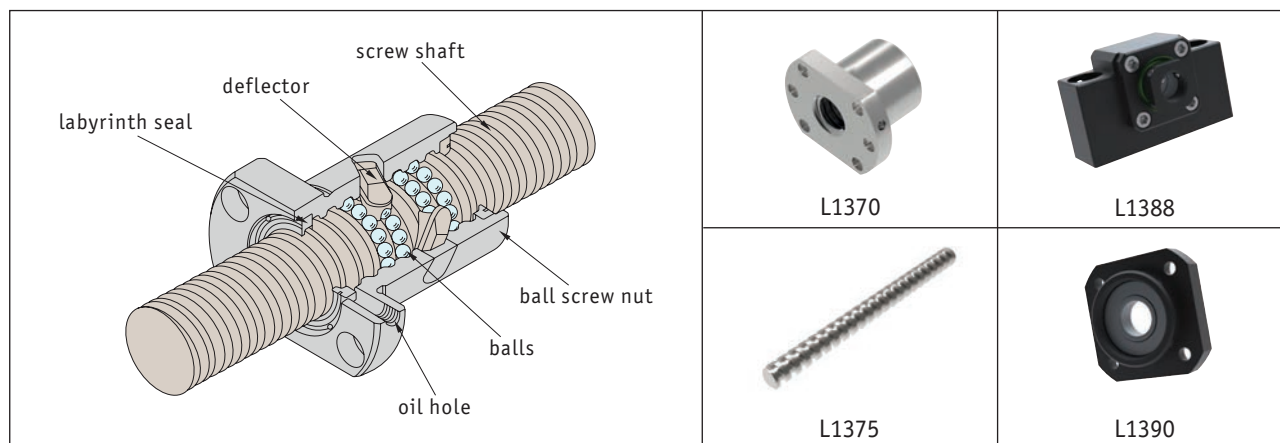

Standard ball screws



Miniature ball screws



Rolled ball screws

Ø	Pitch (travel per revolution)						
	5	10	16	20	25	40	50
16	●	●	●				
20	●	●		●			
25	●	●			●		
32	●	●		●			
40	●	●		●		●	
50		●		●			●
63		●		●			
80		●		●			

Miniature ball screws

Ø	Pitch (travel per revolution)					Nut
	1	2	2.5	4	5	
6	●					flanged
8	●	●	●			flanged
10		●		●		flanged/cylinder
12		●		●	●	flanged/cylinder
14		●				flanged/cylinder



When selecting a ball screw some of the main factors to consider are:

- Maximum required travel speed
- Maximum axial compression (buckling load)
- Method of support of the ball screws
- Type of unit required, flanged, cylindrical etc.

In general it is best to support the ball screws with our ball screw support units (L1388 to L1406) with a fixed end (generally where the motor is mounted) and a floating (support) end. The support units are selected to suit the loads likely to be required, the size of the ball screw (especially its core diameter) and the type of mounting required. Details of the machining required for each end of the ball screw are shown in the bearing mounts technical section.

The data table for the ball screws show the diameter, the lead of the ball screw (i.e. how far the nut travels for one complete revolution of the screw) as well as the mass moment of inertia (also known as the rotational moment of inertia) - this is the extent to which an object resists rotational acceleration about its axis.

Maximum speeds and buckling load data are shown in the technical pages.

When using a ball screw the ambient temperature should not exceed +80°C.

During assembly, the parallel alignment of the guides should be ensure.

The details on the concentricity of the ball nuts to the ball screws are shown on the technical pages. For linear guideways for use with ball screws please see our part numbers L1016 etc.

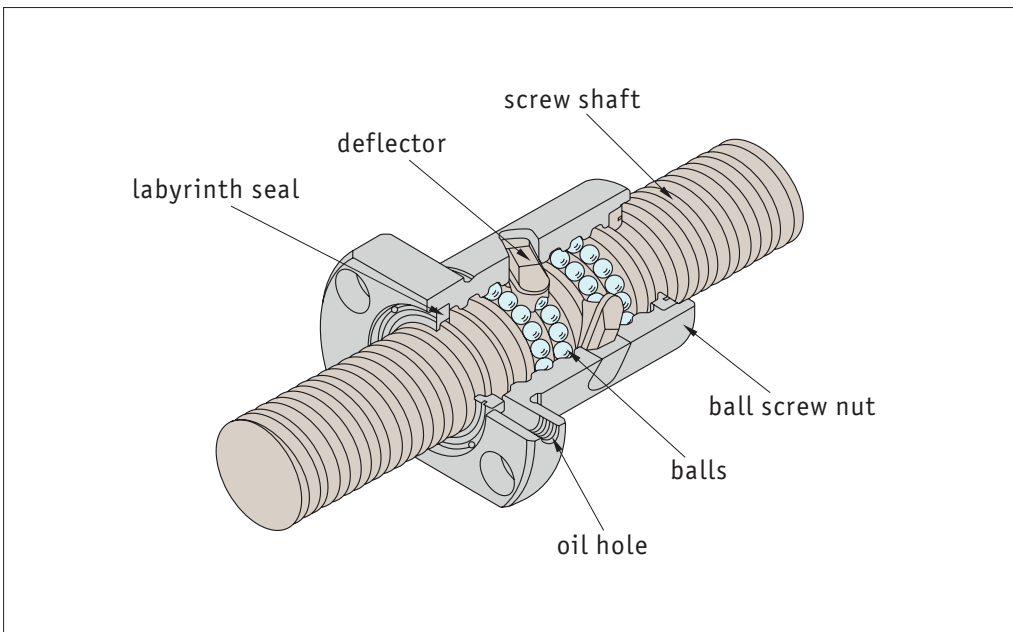

Lubrication - the ball screws must be adequately lubricated. This is dependent on load, speed, motion sequence and temperature. Do not use lubricants containing Mo/So or graphite.



In general, the ball nut is already on the ball screw and should not be removed. If you need to machine the ball screw, then the plastic mounting sleeve should be used to retain the ball bearings whilst the nut is removed.

Mounting the nut on the screw

Sometimes ball screws are delivered with a separate ball nut. When mounting the nut on to the screw take care as if done incorrectly the ball bearings may come off the ball nut.

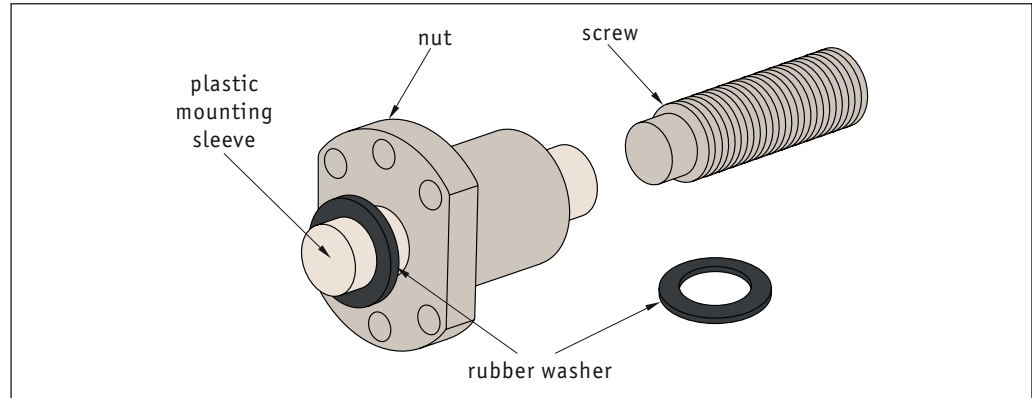

Ball nuts should be mounted only with the help of a plastic mounting sleeve (delivered with the nut). The start of the thread should be aligned so that the seal and the internal parts of the nut are not damaged.

1. Remove the rubber washer from one side of the sleeve. Push on the nut with the sleeve on the end of the screw. Press the sleeve against the start of the screw thread.
2. Screw the nut onto the thread using a slight axial pressure, then screw the nut on for its entire length.
3. Remove the mounting sleeve only when the nut is completely threaded on to the screw.
4. Lock the nut on to the screw (to prevent any unscrewing) using an O ring or similar - whilst installing the system.

If the balls do unfortunately escape...

1. Pick them up (the nut is only compatible with the original balls). The load capacity can still be achieved if one or two balls are missing.
2. Carefully clean all parts, use the sleeve as a mounting jig and replace the balls.
3. Start with the lowest circuit. Insert the balls into the nut circuit - the sleeve prevents the balls from falling out again.
4. Do not place the balls in the empty circuit located between the two deflectors.

If you have any technical queries please call **0333 207 4498**.



Ball Screws

Maximum axial loads

Ball Screws



The maximum axial loads are the loads at which a ball screw will not buckle under compressive loads in the axial direction.

For ease of use the total maximum axial loads are shown in the following graphs.

Factors are:

- Type of supports
- Screw diameter (core)
- Length between supports

Apply 50% to the graph figures - to provide a margin of safety.

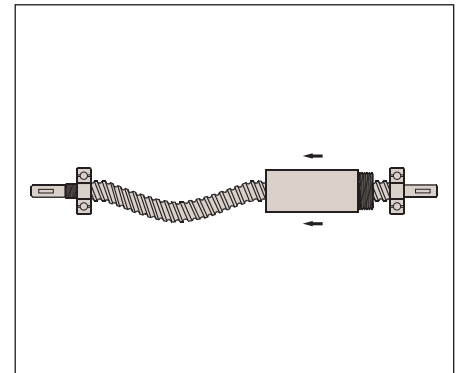

$$F_b = \frac{\alpha \cdot \eta_1 \cdot \pi^2 \cdot E \cdot I}{L^2}$$

Factors		
	η_1	η_2
Fixed-floating	2	10
Fixed-fixed	4	20
Fixed-free	0,25	1,3

- F_b = buckling load (N)
- α = safety factor 0.5
- E = Young's modulus 2.06×10^5 (N/mm²)
- L = distance between supports
- I = area moment of inertia
- $I = \frac{\pi}{64} \times d_c^4$
- d_c = Core \varnothing of screw

A ball screw of size 40 \varnothing . This has a core diameter of 35.8mm.

Distance between the support parts is 600mm.

Using a fixed and floating bearing arrangement.

Reading of graph 1 (fixed-floating) the maximum axial load is going to be 50,000 N (approximately 5 tons).

Example:

Area moment of inertia

$$I = \frac{\pi}{64} \times d_c^4$$

$$= \frac{\pi}{64} \times 33.2^4$$

$$= 59.638 \text{mm}^4$$

Buckling load calculation

- Method 1

Safety factor

η_1 factor - see table above

$$F_b = \frac{0.5 \cdot 2 \cdot \pi^2 \cdot E \cdot I}{L^2}$$

$$= 0.5 \times 2 \times 3.14^2 \times 600^2 (206,000) \times 59,638$$

$$= 337 \text{ kN}$$

Buckling load calculation

- Method 2

$$F_b = \eta^2 \cdot \frac{d_c^4}{L^2} \cdot 10^4$$

η_2 factor - see table above

$$= 10 \times \frac{(33.2)^4 \times 10^4}{600^2}$$

$$= 337 \text{ kN}$$

Buckling load - check graph

Gives max. load = 370kN