

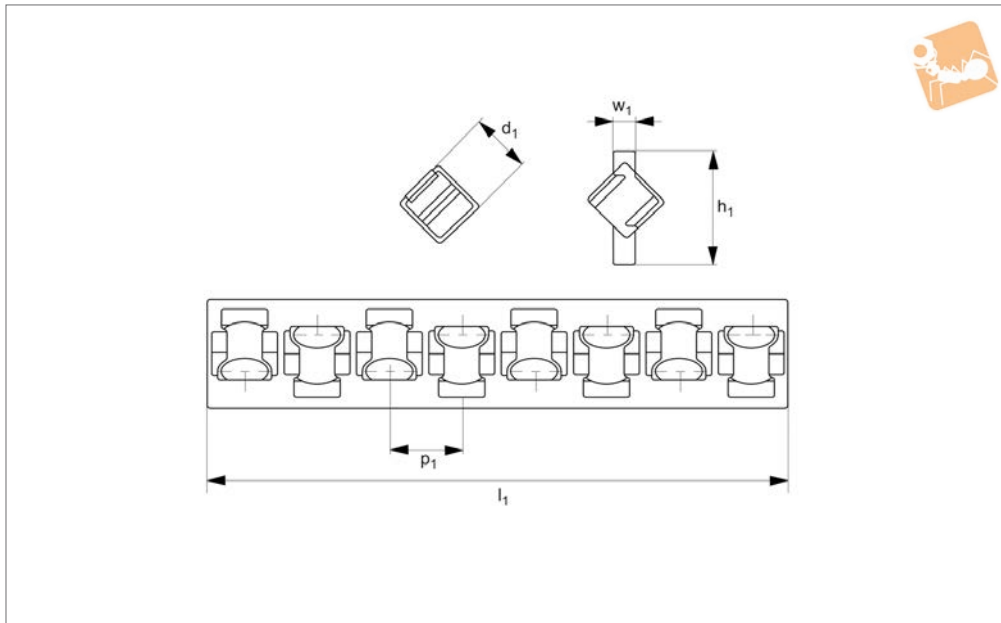

# Linear Cage - Crossed Roller plastic cage

## Ball & Needle Cages



**L1008.060-PR**

BALL & NEEDLE CAGES

### Material

Steel rollers (100Cr6, class 3, hardened to 60 HRC) retaining cage plastic (PA 12).

### Important Notes

For load ratings calculations the maximum recommended load is 1/3 of the max. static

load.

Order No.	$d_1$	$p_1$	$h_1$	$l_1$	$w_1$	No. of rollers	Dyn. load C N max.
L1008.060-PR-0100	6	8.5	14	100	2	11	583
L1008.060-PR-0200	6	8.5	14	200	2	23	12190
L1008.060-PR-0300	6	8.5	14	300	2	35	18550
L1008.060-PR-0400	6	8.5	14	400	2	46	24380
L1008.060-PR-0500	6	8.5	14	500	2	58	30740
L1008.060-PR-0600	6	8.5	14	600	2	70	37100
L1008.060-PR-0700	6	8.5	14	700	2	81	42930
L1008.060-PR-0800	6	8.5	14	800	2	93	49290
L1008.060-PR-0900	6	8.5	14	900	2	105	55650
L1008.060-PR-1000	6	8.5	14	1000	2	117	62010