

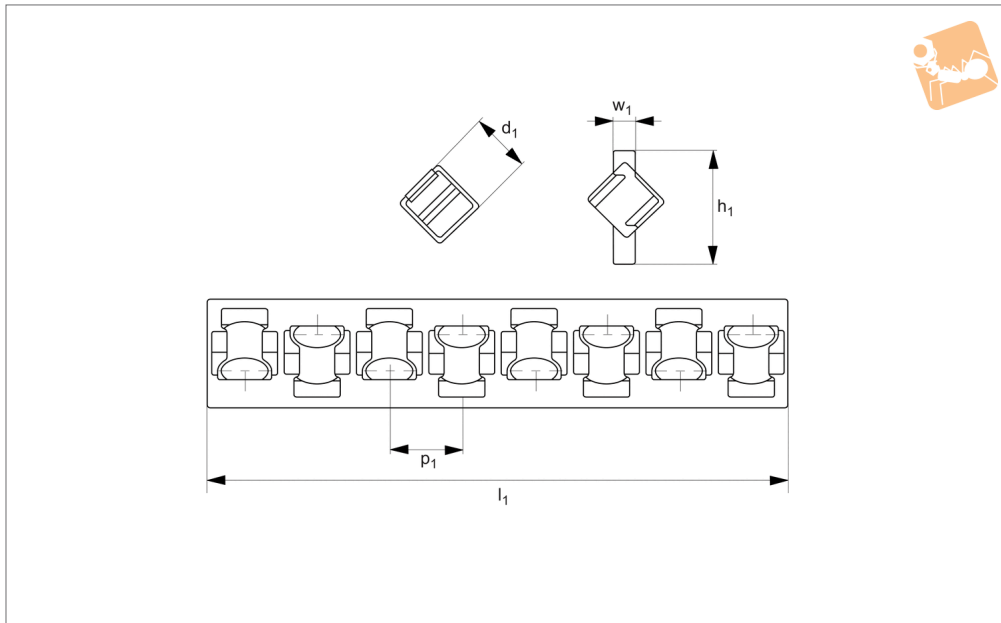

Linear Cage - Crossed Roller

stainless steel cage

Ball & Needle Cages



L1008.015-SS

BALL & NEEDLE CAGES

Material

Stainless rollers (440C), stainless cage (AISI 304).

Important Notes

For load ratings calculations the maximum recommended load is 1/3 of the max. static

load.

Order No.	d_1	p_1	h_1	l_1	w_1	No. of rollers	Dyn. load C N max.
L1008.015-SS-0100	1.5	3	3.75	100	0.2	32	4042
L1008.015-SS-0200	1.5	3	3.75	200	0.2	66	8206
L1008.015-SS-0300	1.5	3	3.75	300	0.2	99	12375
L1008.015-SS-0400	1.5	3	3.75	400	0.2	132	16542
L1008.015-SS-0500	1.5	3	3.75	500	0.2	166	20708
L1008.015-SS-0600	1.5	3	3.75	600	0.2	199	24875
L1008.015-SS-0700	1.5	3	3.75	700	0.2	232	29042
L1008.015-SS-0800	1.5	3	3.75	800	0.2	266	33208
L1008.015-SS-0900	1.5	3	3.75	900	0.2	299	37375
L1008.015-SS-1000	1.5	3	3.75	1000	0.2	332	41542