

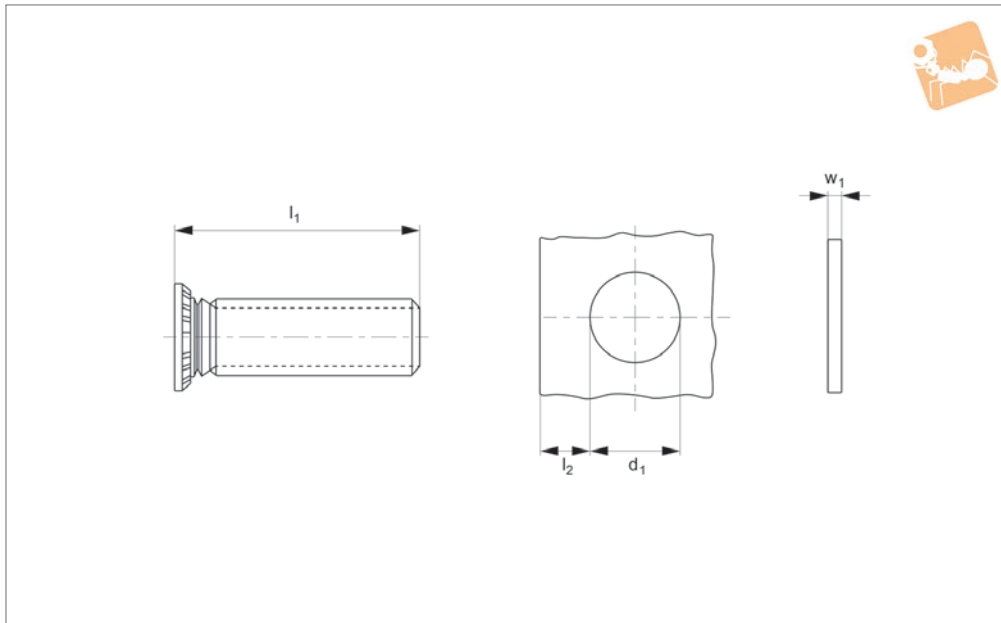

Clinch Studs

Steel, zinc-plated

Clinch Studs



P0835.ZP

CLINCH STUDS

Material

Steel, zinc-plated.

Technical Notes

Clinch studs provide a strong male thread

in sheet metal materials. They are squeezed into place using a press whilst supporting the reverse side. They provide a flush finish on the reverse side.

l_2 - minimum distance from edge of metal.

Order No.	For thread	d_1	l_1	l_2	w_1 min.	Material
P0835.020-006-ZP	M2	2.0	6	5.0	1.0	Steel ZP
P0835.020-008-ZP	M2	2.0	8	5.0	1.0	Steel ZP
P0835.020-010-ZP	M2	2.0	10	5.0	1.0	Steel ZP
P0835.020-012-ZP	M2	2.0	12	5.0	1.0	Steel ZP
P0835.020-014-ZP	M2	2.0	14	5.0	1.0	Steel ZP
P0835.020-015-ZP	M2	2.0	15	5.0	1.0	Steel ZP
P0835.020-016-ZP	M2	2.0	16	5.0	1.0	Steel ZP
P0835.025-006-ZP	M2,5	2.5	6	5.4	1.0	Steel ZP
P0835.025-008-ZP	M2,5	2.5	8	5.4	1.0	Steel ZP
P0835.025-010-ZP	M2,5	2.5	10	5.4	1.0	Steel ZP
P0835.025-012-ZP	M2,5	2.5	12	5.4	1.0	Steel ZP
P0835.025-014-ZP	M2,5	2.5	14	5.4	1.0	Steel ZP
P0835.025-015-ZP	M2,5	2.5	15	5.4	1.0	Steel ZP
P0835.025-016-ZP	M2,5	2.5	16	5.4	1.0	Steel ZP
P0835.025-018-ZP	M2,5	2.5	18	5.4	1.0	Steel ZP
P0835.030-006-ZP	M3	3.0	6	5.6	1.0	Steel ZP
P0835.030-008-ZP	M3	3.0	8	5.6	1.0	Steel ZP
P0835.030-010-ZP	M3	3.0	10	5.6	1.0	Steel ZP
P0835.030-012-ZP	M3	3.0	12	5.6	1.0	Steel ZP
P0835.030-014-ZP	M3	3.0	14	5.6	1.0	Steel ZP
P0835.030-015-ZP	M3	3.0	15	5.6	1.0	Steel ZP
P0835.030-016-ZP	M3	3.0	16	5.6	1.0	Steel ZP
P0835.030-018-ZP	M3	3.0	18	5.6	1.0	Steel ZP
P0835.030-020-ZP	M3	3.0	20	5.6	1.0	Steel ZP
P0835.030-022-ZP	M3	3.0	22	5.6	1.0	Steel ZP
P0835.030-025-ZP	M3	3.0	25	5.6	1.0	Steel ZP
P0835.030-030-ZP	M3	3.0	30	5.6	1.0	Steel ZP
P0835.030-035-ZP	M3	3.0	35	5.6	1.0	Steel ZP
P0835.035-008-ZP	M3,5	3.5	8	6.4	1.0	Steel ZP
P0835.035-010-ZP	M3,5	3.5	10	6.4	1.0	Steel ZP
P0835.035-012-ZP	M3,5	3.5	12	6.4	1.0	Steel ZP
P0835.035-014-ZP	M3,5	3.5	14	6.4	1.0	Steel ZP
P0835.035-015-ZP	M3,5	3.5	15	6.4	1.0	Steel ZP
P0835.035-016-ZP	M3,5	3.5	16	6.4	1.0	Steel ZP



Order No.	For thread	d ₁	l ₁	l ₂	w ₁ min.	Material
P0835.035-018-ZP	M3,5	3.5	18	6.4	1.0	Steel ZP
P0835.040-006-ZP	M4	4.0	6	7.2	1.0	Steel ZP
P0835.040-008-ZP	M4	4.0	8	7.2	1.0	Steel ZP
P0835.040-010-ZP	M4	4.0	10	7.2	1.0	Steel ZP
P0835.040-012-ZP	M4	4.0	12	7.2	1.0	Steel ZP
P0835.040-014-ZP	M4	4.0	14	7.2	1.0	Steel ZP
P0835.040-015-ZP	M4	4.0	15	7.2	1.0	Steel ZP
P0835.040-016-ZP	M4	4.0	16	7.2	1.0	Steel ZP
P0835.040-018-ZP	M4	4.0	18	7.2	1.0	Steel ZP
P0835.040-020-ZP	M4	4.0	20	7.2	1.0	Steel ZP
P0835.040-022-ZP	M4	4.0	22	7.2	1.0	Steel ZP
P0835.040-025-ZP	M4	4.0	25	7.2	1.0	Steel ZP
P0835.040-030-ZP	M4	4.0	30	7.2	1.0	Steel ZP
P0835.040-035-ZP	M4	4.0	35	7.2	1.0	Steel ZP
P0835.040-038-ZP	M4	4.0	38	7.2	1.0	Steel ZP
P0835.040-040-ZP	M4	4.0	40	7.2	1.0	Steel ZP
P0835.040-045-ZP	M4	4.0	45	7.2	1.0	Steel ZP
P0835.040-050-ZP	M4	4.0	50	7.2	1.0	Steel ZP
P0835.050-008-ZP	M5	5.0	8	7.2	1.0	Steel ZP
P0835.050-010-ZP	M5	5.0	10	7.2	1.0	Steel ZP
P0835.050-012-ZP	M5	5.0	12	7.2	1.0	Steel ZP
P0835.050-014-ZP	M5	5.0	14	7.2	1.0	Steel ZP
P0835.050-015-ZP	M5	5.0	15	7.2	1.0	Steel ZP
P0835.050-016-ZP	M5	5.0	16	7.2	1.0	Steel ZP
P0835.050-018-ZP	M5	5.0	18	7.2	1.0	Steel ZP
P0835.050-020-ZP	M5	5.0	20	7.2	1.0	Steel ZP
P0835.050-022-ZP	M5	5.0	22	7.2	1.0	Steel ZP
P0835.050-025-ZP	M5	5.0	25	7.2	1.0	Steel ZP
P0835.050-030-ZP	M5	5.0	30	7.2	1.0	Steel ZP
P0835.050-035-ZP	M5	5.0	35	7.2	1.0	Steel ZP
P0835.050-038-ZP	M5	5.0	38	7.2	1.0	Steel ZP
P0835.050-040-ZP	M5	5.0	40	7.2	1.0	Steel ZP
P0835.050-045-ZP	M5	5.0	45	7.2	1.0	Steel ZP
P0835.050-050-ZP	M5	5.0	50	7.2	1.0	Steel ZP
P0835.060-008-ZP	M6	6.0	8	7.9	1.6	Steel ZP
P0835.060-010-ZP	M6	6.0	10	7.9	1.6	Steel ZP
P0835.060-012-ZP	M6	6.0	12	7.9	1.6	Steel ZP
P0835.060-014-ZP	M6	6.0	14	7.9	1.6	Steel ZP
P0835.060-015-ZP	M6	6.0	15	7.9	1.6	Steel ZP
P0835.060-016-ZP	M6	6.0	16	7.9	1.6	Steel ZP
P0835.060-018-ZP	M6	6.0	18	7.9	1.6	Steel ZP
P0835.060-020-ZP	M6	6.0	20	7.9	1.6	Steel ZP
P0835.060-022-ZP	M6	6.0	22	7.9	1.6	Steel ZP
P0835.060-025-ZP	M6	6.0	25	7.9	1.6	Steel ZP
P0835.060-030-ZP	M6	6.0	30	7.9	1.6	Steel ZP
P0835.060-035-ZP	M6	6.0	35	7.9	1.6	Steel ZP
P0835.060-038-ZP	M6	6.0	38	7.9	1.6	Steel ZP
P0835.060-040-ZP	M6	6.0	40	7.9	1.6	Steel ZP
P0835.060-045-ZP	M6	6.0	45	7.9	1.6	Steel ZP
P0835.060-050-ZP	M6	6.0	50	7.9	1.6	Steel ZP
P0835.080-012-ZP	M8	8.0	12	9.6	2.4	Steel ZP
P0835.080-014-ZP	M8	8.0	14	9.6	2.4	Steel ZP
P0835.080-015-ZP	M8	8.0	15	9.6	2.4	Steel ZP
P0835.080-016-ZP	M8	8.0	16	9.6	2.4	Steel ZP
P0835.080-018-ZP	M8	8.0	18	9.6	2.4	Steel ZP
P0835.080-020-ZP	M8	8.0	20	9.6	2.4	Steel ZP
P0835.080-022-ZP	M8	8.0	22	9.6	2.4	Steel ZP
P0835.080-025-ZP	M8	8.0	25	9.6	2.4	Steel ZP
P0835.080-030-ZP	M8	8.0	30	9.6	2.4	Steel ZP
P0835.080-035-ZP	M8	8.0	35	9.6	2.4	Steel ZP
P0835.080-038-ZP	M8	8.0	38	9.6	2.4	Steel ZP
P0835.080-040-ZP	M8	8.0	40	9.6	2.4	Steel ZP
P0835.080-045-ZP	M8	8.0	45	9.6	2.4	Steel ZP
P0835.080-050-ZP	M8	8.0	50	9.6	2.4	Steel ZP
P0835.080-060-ZP	M8	8.0	60	9.6	2.4	Steel ZP



Clinch Studs

A2 Stainless

Clinch Studs

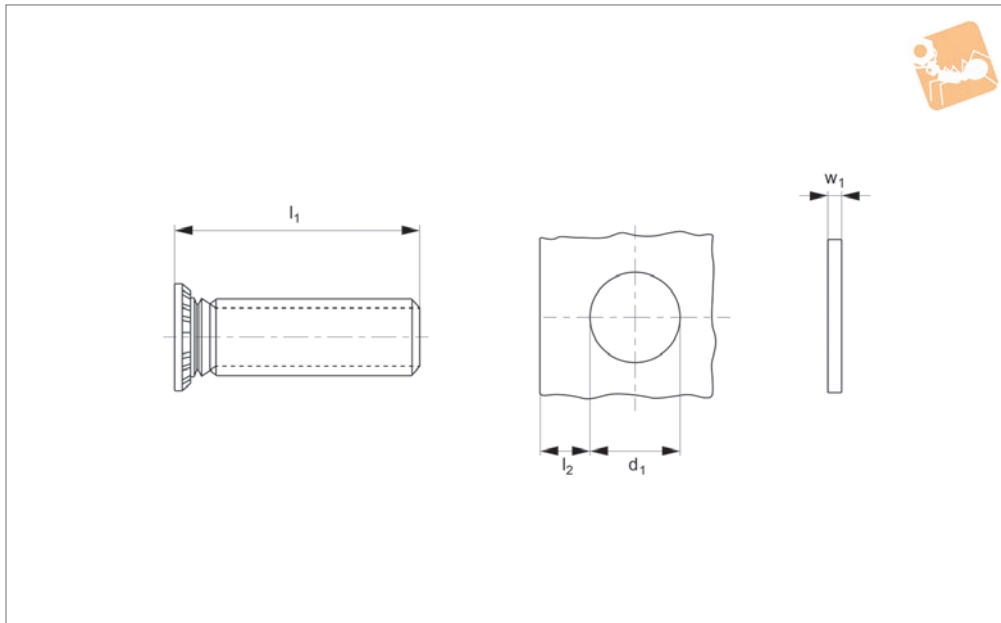

P0835.A2

CLINCH STUDS

Material

Stainless steel (A2, AISI 303).

Technical Notes

Clinch studs provide a strong male thread

in sheet metal materials. They are squeezed into place using a press whilst supporting the reverse side. They provide a flush finish on the reverse side.

Stainless clinch studs are suitable for use with material up to HRB 70 hardness. l_2 - minimum distance from edge of metal.

Order No.	For thread	d_1	l_1	l_2	w_1 min.	Material
P0835.025-006-A2	M2,5	2.5	6	5.4	1.0	A2 s/s
P0835.025-008-A2	M2,5	2.5	8	5.4	1.0	A2 s/s
P0835.025-010-A2	M2,5	2.5	10	5.4	1.0	A2 s/s
P0835.025-012-A2	M2,5	2.5	12	5.4	1.0	A2 s/s
P0835.025-014-A2	M2,5	2.5	14	5.4	1.0	A2 s/s
P0835.025-015-A2	M2,5	2.5	15	5.4	1.0	A2 s/s
P0835.025-016-A2	M2,5	2.5	16	5.4	1.0	A2 s/s
P0835.025-018-A2	M2,5	2.5	18	5.4	1.0	A2 s/s
P0835.030-006-A2	M3	3.0	6	5.6	1.0	A2 s/s
P0835.030-008-A2	M3	3.0	8	5.6	1.0	A2 s/s
P0835.030-010-A2	M3	3.0	10	5.6	1.0	A2 s/s
P0835.030-012-A2	M3	3.0	12	5.6	1.0	A2 s/s
P0835.030-014-A2	M3	3.0	14	5.6	1.0	A2 s/s
P0835.030-015-A2	M3	3.0	15	5.6	1.0	A2 s/s
P0835.030-016-A2	M3	3.0	16	5.6	1.0	A2 s/s
P0835.030-018-A2	M3	3.0	18	5.6	1.0	A2 s/s
P0835.030-020-A2	M3	3.0	20	5.6	1.0	A2 s/s
P0835.030-022-A2	M3	3.0	22	5.6	1.0	A2 s/s
P0835.030-025-A2	M3	3.0	25	5.6	1.0	A2 s/s
P0835.030-030-A2	M3	3.0	30	5.6	1.0	A2 s/s
P0835.030-035-A2	M3	3.0	35	5.6	1.0	A2 s/s
P0835.035-008-A2	M3,5	3.5	8	6.4	1.0	A2 s/s
P0835.035-010-A2	M3,5	3.5	10	6.4	1.0	A2 s/s
P0835.035-012-A2	M3,5	3.5	12	6.4	1.0	A2 s/s
P0835.035-014-A2	M3,5	3.5	14	6.4	1.0	A2 s/s
P0835.035-015-A2	M3,5	3.5	15	6.4	1.0	A2 s/s
P0835.035-016-A2	M3,5	3.5	16	6.4	1.0	A2 s/s
P0835.035-018-A2	M3,5	3.5	18	6.4	1.0	A2 s/s
P0835.040-006-A2	M4	4.0	6	7.2	1.0	A2 s/s
P0835.040-008-A2	M4	4.0	8	7.2	1.0	A2 s/s
P0835.040-010-A2	M4	4.0	10	7.2	1.0	A2 s/s
P0835.040-012-A2	M4	4.0	12	7.2	1.0	A2 s/s
P0835.040-014-A2	M4	4.0	14	7.2	1.0	A2 s/s
P0835.040-015-A2	M4	4.0	15	7.2	1.0	A2 s/s



CLINCH STUDS

Order No.	For thread	d ₁	l ₁	l ₂	w ₁ min.	Material
P0835.040-016-A2	M4	4.0	16	7.2	1.0	A2 s/s
P0835.040-018-A2	M4	4.0	18	7.2	1.0	A2 s/s
P0835.040-020-A2	M4	4.0	20	7.2	1.0	A2 s/s
P0835.040-022-A2	M4	4.0	22	7.2	1.0	A2 s/s
P0835.040-025-A2	M4	4.0	25	7.2	1.0	A2 s/s
P0835.040-030-A2	M4	4.0	30	7.2	1.0	A2 s/s
P0835.040-035-A2	M4	4.0	35	7.2	1.0	A2 s/s
P0835.040-038-A2	M4	4.0	38	7.2	1.0	A2 s/s
P0835.040-040-A2	M4	4.0	40	7.2	1.0	A2 s/s
P0835.040-045-A2	M4	4.0	45	7.2	1.0	A2 s/s
P0835.040-050-A2	M4	4.0	50	7.2	1.0	A2 s/s
P0835.050-008-A2	M5	5.0	8	7.2	1.0	A2 s/s
P0835.050-010-A2	M5	5.0	10	7.2	1.0	A2 s/s
P0835.050-012-A2	M5	5.0	12	7.2	1.0	A2 s/s
P0835.050-014-A2	M5	5.0	14	7.2	1.0	A2 s/s
P0835.050-015-A2	M5	5.0	15	7.2	1.0	A2 s/s
P0835.050-016-A2	M5	5.0	16	7.2	1.0	A2 s/s
P0835.050-018-A2	M5	5.0	18	7.2	1.0	A2 s/s
P0835.050-020-A2	M5	5.0	20	7.2	1.0	A2 s/s
P0835.050-022-A2	M5	5.0	22	7.2	1.0	A2 s/s
P0835.050-025-A2	M5	5.0	25	7.2	1.0	A2 s/s
P0835.050-030-A2	M5	5.0	30	7.2	1.0	A2 s/s
P0835.050-035-A2	M5	5.0	35	7.2	1.0	A2 s/s
P0835.050-038-A2	M5	5.0	38	7.2	1.0	A2 s/s
P0835.060-010-A2	M6	6.0	10	7.9	1.6	A2 s/s
P0835.060-012-A2	M6	6.0	12	7.9	1.6	A2 s/s
P0835.060-014-A2	M6	6.0	14	7.9	1.6	A2 s/s
P0835.060-015-A2	M6	6.0	15	7.9	1.6	A2 s/s
P0835.060-016-A2	M6	6.0	16	7.9	1.6	A2 s/s
P0835.060-018-A2	M6	6.0	18	7.9	1.6	A2 s/s
P0835.060-020-A2	M6	6.0	20	7.9	1.6	A2 s/s
P0835.060-022-A2	M6	6.0	22	7.9	1.6	A2 s/s
P0835.060-025-A2	M6	6.0	25	7.9	1.6	A2 s/s
P0835.060-030-A2	M6	6.0	30	7.9	1.6	A2 s/s
P0835.060-035-A2	M6	6.0	35	7.9	1.6	A2 s/s
P0835.060-038-A2	M6	6.0	38	7.9	1.6	A2 s/s
P0835.060-040-A2	M6	6.0	40	7.9	1.6	A2 s/s
P0835.060-045-A2	M6	6.0	45	7.9	1.6	A2 s/s
P0835.060-050-A2	M6	6.0	50	7.9	1.6	A2 s/s
P0835.080-012-A2	M8	8.0	12	9.6	2.4	A2 s/s
P0835.080-014-A2	M8	8.0	14	9.6	2.4	A2 s/s
P0835.080-015-A2	M8	8.0	15	9.6	2.4	A2 s/s
P0835.080-016-A2	M8	8.0	16	9.6	2.4	A2 s/s
P0835.080-018-A2	M8	8.0	18	9.6	2.4	A2 s/s
P0835.080-020-A2	M8	8.0	20	9.6	2.4	A2 s/s
P0835.080-022-A2	M8	8.0	22	9.6	2.4	A2 s/s
P0835.080-025-A2	M8	8.0	25	9.6	2.4	A2 s/s
P0835.080-030-A2	M8	8.0	30	9.6	2.4	A2 s/s
P0835.080-035-A2	M8	8.0	35	9.6	2.4	A2 s/s
P0835.080-038-A2	M8	8.0	38	9.6	2.4	A2 s/s
P0835.080-040-A2	M8	8.0	40	9.6	2.4	A2 s/s
P0835.080-045-A2	M8	8.0	45	9.6	2.4	A2 s/s
P0835.080-050-A2	M8	8.0	50	9.6	2.4	A2 s/s