

Standard cross roller rail sets

L1000 & L1001

- Seven rail profiles (Sizes 1-12)
- Lengths: 20mm to 1 metre
- L1000 standard rail set
- L1001 corrosion resistant rail sets

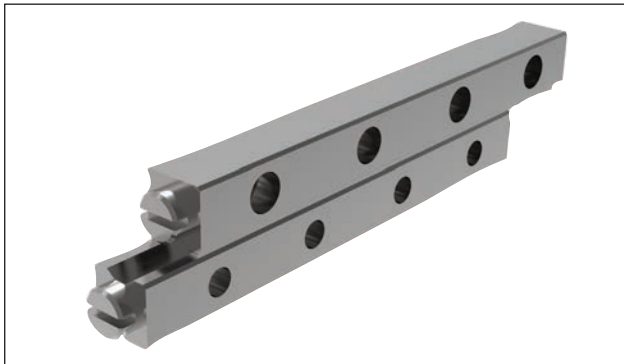

Deep groove and anti-creep rail sets

L1002 + L1003

- 3 x load capacity of standard rail sets (due to deep V groove)
- Two rail profiles (Sizes 4 & 6)
- Lengths 50mm to 400mm
- Anti-creep versions for high acceleration applications



Needle roller rail sets

L1004

- Heavy load ratings and needle rollers are used
- Five rail profile size
- Lengths: 200mm to 1.2 metres

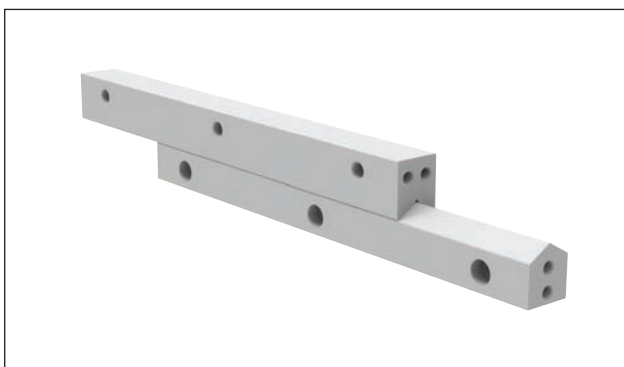

Anti-friction coated rail sets

L1005 & L1006

- Same profile as needle roller rails but contact face Teflon coated.
- Ideal for harsh, dirty conditions
- Vibration damping characteristics



L1004.HW

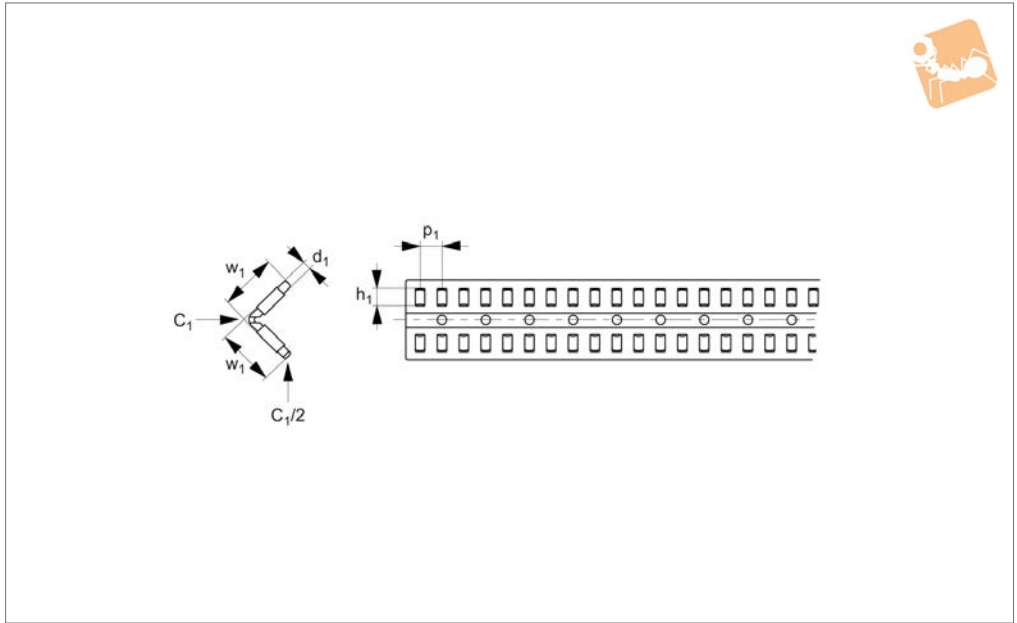

Material

Steel rollers (100Cr6, hardened to 60 HRC), aluminium retaining cage (apart from L1004.HW10 - steel).

Technical Notes

When ordering please specify the length

required (must be a multiple of pitch, p).

Supplied in max. 1 metre lengths.

Ordering example:

L1004.HW15-030 is a 3mm diameter roller strip 45mm long with 30 rollers (as 10xp = 45mm).

Tips

See technical pages for load rating calculations - based on rail size and number of rollers in the system cages.

Order No.	d_1 ± 0.001	p_1	h_1	w_1	Dyn. load C /pair of rollers N max.	To suit rail
L1004.HW10-xxx	2.0	4.0	4.8	10	2.500	L1004.22
L1004.HW15-xxx	2.0	4.5	6.8	15	4.000	L1004.25
L1004.HW20xxx	2.5	5.5	9.8	20	7.300	L1004.30
L1004.HW25-xxx	3.0	6.0	13.8	25	12.500	L1004.35
L1004.HW30-xxx	3.5	7.0	17.8	30	18.500	L1004.45

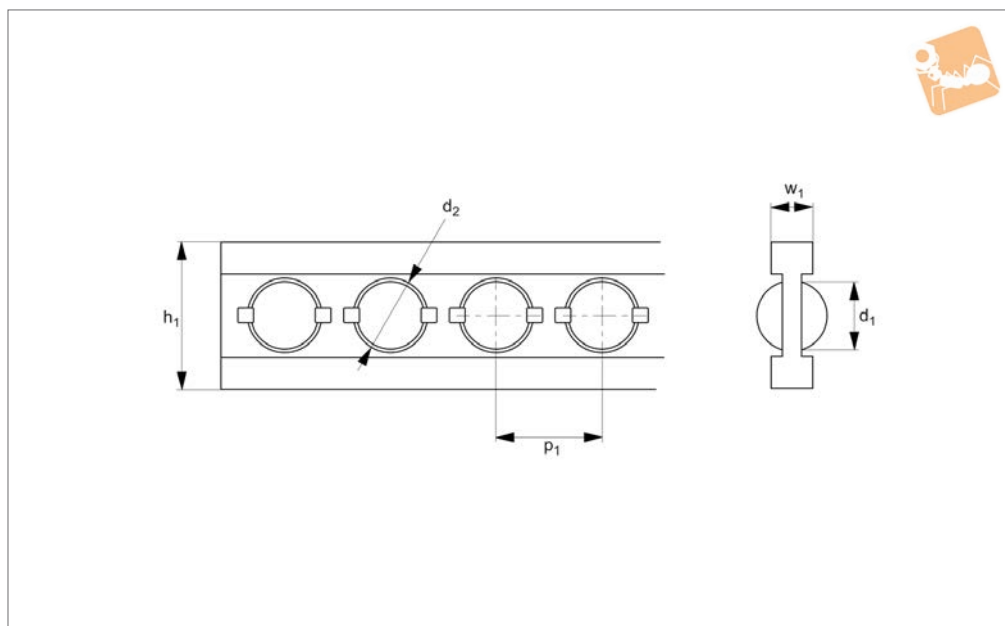

L1007

BALL & NEEDLE CAGES

Material

Ball steel (100Cr6 to DIN 5401, class 3), ball cage plastic (PA 12).
Can also be supplied with corrosion resistant stainless balls (AISI 304) balls, plastic balls (POM) or ceramic balls.

Technical Notes

When ordering please specify the length required (must be a multiple of pitch, p).
Supplied in max. 1 metre lengths.

Tips

Ordering example:
L1007.030-020 is a 3mm diameter ball strip length 84mm with 20 rollers (as 20xp = 84mm).

Order No.	d ₁	p ₁	h ₁	w ₁	d ₂
L1007.020-xxx	2.0	3.0	5.0	0.75	2.1
L1007.030-xxx	3.0	4.2	7.0	1.00	3.2
L1007.040-xxx	4.0	5.8	6.3	1.30	4.2
L1007.050-xxx	5.0	6.8	8.0	1.50	5.2
L1007.060-xxx	6.0	7.8	9.0	1.60	6.2
L1007.080-xxx	8.0	12.0	12.0	2.00	8.2
L1007.090-xxx	9.0	11.5	15.0	2.00	9.2
L1007.100-xxx	10.0	12.5	13.2	2.50	10.2
L1007.110-xxx	11.0	14.0	13.7	2.50	11.2
L1007.120-xxx	12.0	15.0	15.0	2.50	12.2
L1007.160-xxx	16.0	20.0	20.0	3.50	16.2



L1008

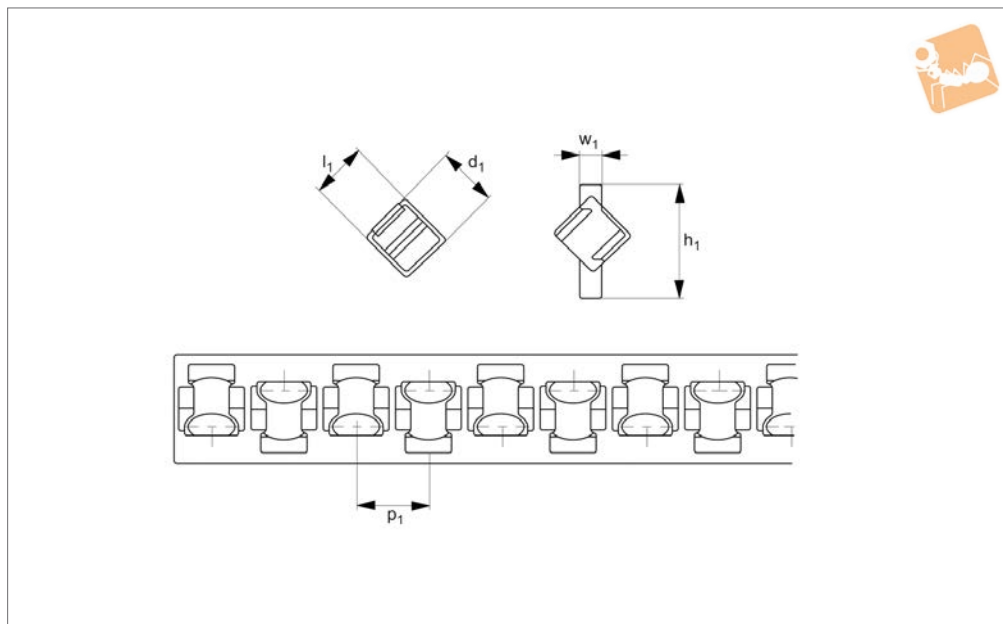

Material

Steel rollers (100Cr6, class 3, hardened to 60 HRC) retaining cage plastic (PA 12) or steel.

Stainless version - stainless rollers (440C), stainless cage (AISI 304).

Technical Notes

When ordering please specify the length

required (must be a multiple of pitch, p).
Supplied in max. 1 metre lengths.

Tips

Ordering example:
L1008.030-PR-010 is a 3mm diameter roller strip 50mm long with 10 rollers (as 10xp = 50mm).

Important Notes

For load ratings calculations the maximum recommended load is 1/3 of the max. static load.

Order No.	d ₁	p ₁	h ₁	w ₁	Dyn. load C N max.	Static load C N max.	Cage material
L1008.020-PR-xxx	2	3.9	5	0.75	290	295	Plastic
L1008.030-PR-xxx	3	5.0	7	1.00	630	760	Plastic
L1008.060-PR-xxx	6	8.5	14	2.00	2500	2600	Plastic
L1008.090-PR-xxx	9	14.0	20	3.00	7100	7200	Plastic
L1008.015-AA-xxx	1.5	3	3.75	0.2	125	144	Steel
L1008.020-AA-xxx	2.0	4	5.50	0.3	290	295	Steel
L1008.030-AA-xxx	3.0	5	7.50	0.4	630	760	Steel
L1008.060-AA-xxx	6.0	9	14.00	0.8	2500	2600	Steel
L1008.090-AA-xxx	9.0	14	20.50	1.0	7100	7274	Steel
L1008.120-AA-xxx	12.0	18	26.50	1.2	12700	13200	Steel
L1008.015-SS-xxx	1.5	3	3.75	0.2	125	144	Stainless
L1008.020-SS-xxx	2.0	4	5.50	0.3	290	295	Stainless
L1008.030-SS-xxx	3.0	5	7.50	0.4	630	760	Stainless
L1008.060-SS-xxx	6.0	9	14.00	0.8	2500	2600	Stainless
L1008.090-SS-xxx	9.0	14	20.50	1.0	7100	7274	Stainless



Linear Cage - Needle Roller

Ball & Needle Cages

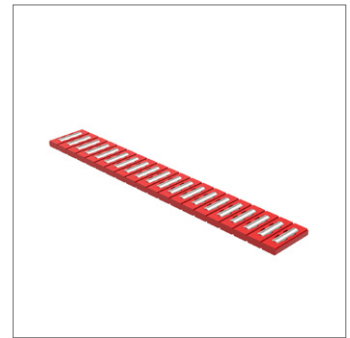
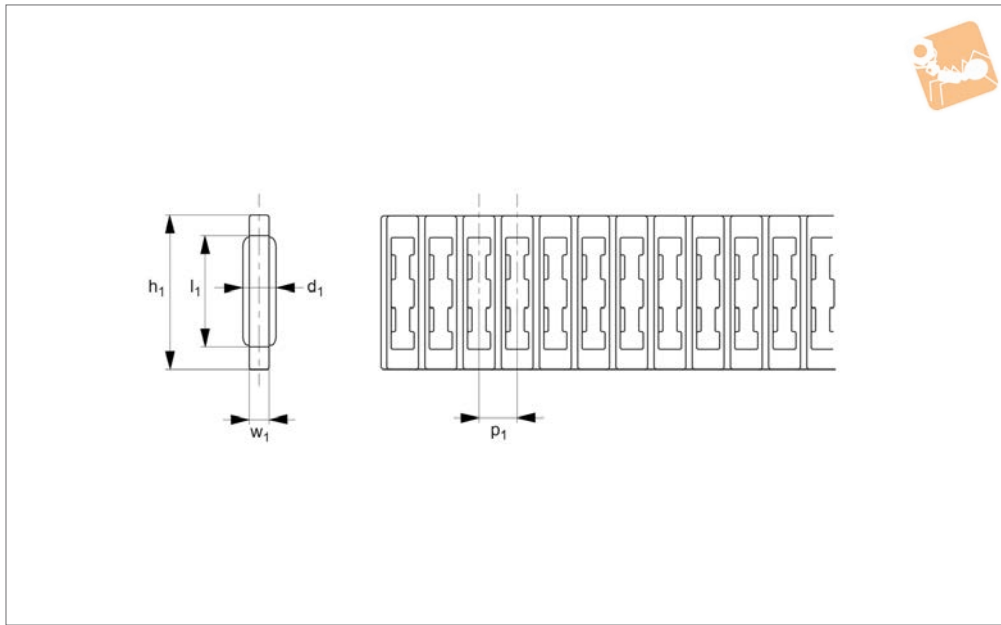

L1009

BALL & NEEDLE CAGES

Material

Needle roller, steel (100Cr6 to DIN5401, grade 28, class 3), retaining cage plastic (PA 12).

required (must be a multiple of pitch, p). = 225mm).
Supplied in max. 1 metre lengths.

Tips

Ordering example:
L1009.050-030 is a 5mm diameter roller strip 225mm long with 30 rollers (as 30xp

Technical Notes

When ordering please specify the length

Order No.	d_1	p_1	h_1	l_1	w_1
L1009.015-xxx	1.5	2.9	10	7.8	1.1
L1009.025-xxx	2.5	4.8	18	13.8	2.0
L1009.030-xxx	3.0	5.2	20	15.8	2.5
L1009.040-xxx	4.0	7.0	30	23.8	3.0
L1009.050-xxx	5.0	7.5	10	5.0	2.5
L1009.051-xxx	5.0	8.0	23	15.0	3.5
L1009.052-xxx	5.0	9.0	35	27.8	3.5
L1009.100-xxx	10.0	13.0	16	10.0	2.5
L1009.120-xxx	12.0	16.0	40	30.0	5.0
L1009.160-xxx	16.0	22.0	28	16.0	4.0