



P1000



Material
Stainless steel DIN 1,4300.

Technical Notes
See tables on page XX for individual machine screw dimensions.

Larger sizes on next page

Machine Screws

Stainless steel

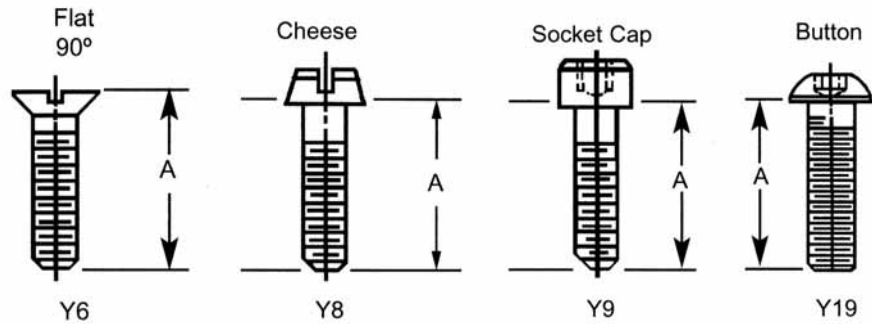

M5 to M10 on next page

Order No. Flat	Order No. Cheese	Order No. Socket	Order No. Button	Thread	Length A
Y6-M1-A4	Y8-M1-A4	Y9-M1-A4	Y19-M1-A4	M1,6 x 0,35	4,0
Y6-M1-A5	Y8-M1-A5	Y9-M1-A5	Y19-M1-A5	M1,6 x 0,35	5,0
Y6-M1-A6	Y8-M1-A6	Y9-M1-A6	Y19-M1-A6	M1,6 x 0,35	6,0
Y6-M1-A8	Y8-M1-A8	Y9-M1-A8	Y19-M1-A8	M1,6 x 0,35	8,0
Y6-M1-A10	Y8-M1-A10	Y9-M1-A10	Y19-M1-A10	M1,6 x 0,35	10,0
Y6-M2-A3	Y8-M2-A3	Y9-M2-A3	Y19-M2-A3	M2 x 0,4	3,0
Y6-M2-A4	Y8-M2-A4	Y9-M2-A4	Y19-M2-A4	M2 x 0,4	4,0
Y6-M2-A5	Y8-M2-A5	Y9-M2-A5	Y19-M2-A5	M2 x 0,4	5,0
Y6-M2-A6	Y8-M2-A6	Y9-M2-A6	Y19-M2-A6	M2 x 0,4	6,0
Y6-M2-A8	Y8-M2-A8	Y9-M2-A8	Y19-M2-A8	M2 x 0,4	8,0
Y6-M2-A10	Y8-M2-A10	Y9-M2-A10	Y19-M2-A10	M2 x 0,4	10,0
Y6-M2-A13	Y8-M2-A13	Y9-M2-A13	Y19-M2-A13	M2 x 0,4	12,0
Y6-M2-A16	Y8-M2-A16	Y9-M2-A16	Y19-M2-A16	M2 x 0,4	16,0
Y6-M2-A20	Y8-M2-A20	Y9-M2-A20	Y19-M2-A20	M2 x 0,4	20,0
Y6-M3-A5	Y8-M3-A5	Y9-M3-A5	Y19-M3-A5	M3 x 0,5	5,0
Y6-M3-A6	Y8-M3-A6	Y9-M3-A6	Y19-M3-A6	M3 x 0,5	6,0
Y6-M3-A8	Y8-M3-A8	Y9-M3-A8	Y19-M3-A8	M3 x 0,5	8,0
Y6-M3-A10	Y8-M3-A10	Y9-M3-A10	Y19-M3-A10	M3 x 0,5	10,0
Y6-M3-A13	Y8-M3-A13	Y9-M3-A13	Y19-M3-A13	M3 x 0,5	12,0
Y6-M3-A16	Y8-M3-A16	Y9-M3-A16	Y19-M3-A16	M3 x 0,5	16,0
Y6-M3-A20	Y8-M3-A20	Y9-M3-A20	Y19-M3-A20	M3 x 0,5	20,0
Y6-M3-A25	Y8-M3-A25	Y9-M3-A25	Y19-M3-A25	M3 x 0,5	25,0
Y6-M4-A30	Y8-M4-A30	Y9-M4-A30	Y19-M3-A30	M3 x 0,5	30,0
Y6-M4-A6	Y8-M4-A6	Y9-M4-A6	Y19-M4-A6	M4 x 0,7	6,0
Y6-M4-A8	Y8-M4-A8	Y9-M4-A8	Y19-M4-A8	M4 x 0,7	8,0
Y6-M4-A10	Y8-M4-A10	Y9-M4-A10	Y19-M4-A10	M4 x 0,7	10,0
Y6-M4-A13	Y8-M4-A13	Y9-M4-A13	Y19-M4-A13	M4 x 0,7	12,0
Y6-M4-A16	Y8-M4-A16	Y9-M4-A16	Y19-M4-A16	M4 x 0,7	16,0
Y6-M4-A20	Y8-M4-A20	Y9-M4-A20	Y19-M4-A20	M4 x 0,7	20,0
Y6-M4-A25	Y8-M4-A25	Y9-M4-A25	Y19-M4-A25	M4 x 0,7	25,0
Y6-M4-A30	Y8-M4-A30	Y9-M4-A30	Y19-M4-A30	M4 x 0,7	30,0
Y6-M4-A35	Y8-M4-A35	Y9-M4-A35	Y19-M4-A35	M4 x 0,7	35,0
Y6-M4-A40	Y8-M4-A40	Y9-M4-A40	Y19-M4-A40	M4 x 0,7	40,0

THREADED FASTENERS



Machine Screws

Stainless steel

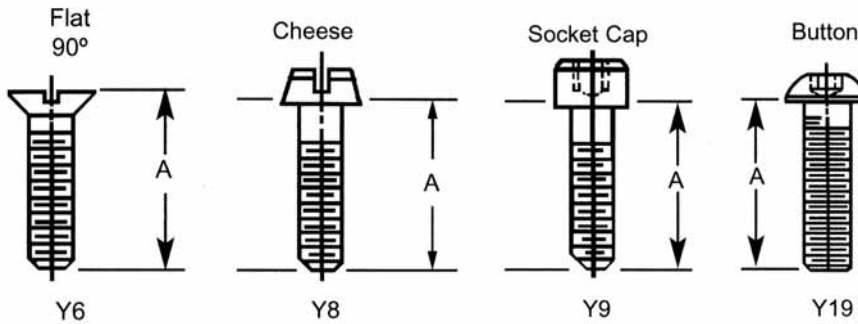

M1,6 to M4 on previous page

Order No. Flat	Order No. Cheese	Order No. Socket	Order No. Button	Thread	Length A
Y6-M5-A4	Y8-M5-A4	Y9-M5-A4	Y19-M5-A4	M5 x 0,8	4,0
Y6-M5-A8	Y8-M5-A8	Y9-M5-A8	Y19-M5-A8	M5 x 0,8	8,0
Y6-M5-A10	Y8-M5-A10	Y9-M5-A10	Y19-M5-A10	M5 x 0,8	10,0
Y6-M5-A13	Y8-M5-A13	Y9-M5-A13	Y19-M5-A13	M5 x 0,8	12,0
Y6-M5-A16	Y8-M5-A16	Y9-M5-A16	Y19-M5-A16	M5 x 0,8	16,0
Y6-M5-A20	Y8-M5-A20	Y9-M5-A20	Y19-M5-A20	M5 x 0,8	20,0
Y6-M5-A25	Y8-M5-A25	Y9-M5-A25	Y19-M5-A25	M5 x 0,8	25,0
Y6-M5-A30	Y8-M5-A30	Y9-M5-A30	Y19-M5-A30	M5 x 0,8	30,0
Y6-M5-A35	Y8-M5-A35	Y9-M5-A35	Y19-M5-A35	M5 x 0,8	35,0
Y6-M5-A40	Y8-M5-A40	Y9-M5-A40	Y19-M5-A40	M5 x 0,8	40,0
Y6-M5-A45	Y8-M5-A45	Y9-M5-A45	Y19-M5-A45	M5 x 0,8	45,0
Y6-M5-A50	Y8-M5-A50	Y9-M5-A50	Y19-M5-A50	M5 x 0,8	50,0
Y6-M6-A8	Y8-M6-A8	Y9-M6-A8	Y19-M6-A8	M6 x 1,0	8,0
Y6-M6-A10	Y8-M6-A10	Y9-M6-A10	Y19-M6-A10	M6 x 1,0	10,0
Y6-M6-A12	Y8-M6-A12	Y9-M6-A12	Y19-M6-A12	M6 x 1,0	12,0
Y6-M6-A16	Y8-M6-A16	Y9-M6-A16	Y19-M6-A16	M6 x 1,0	16,0
Y6-M6-A20	Y8-M6-A20	Y9-M6-A20	Y19-M6-A20	M6 x 1,0	20,0
Y6-M6-A25	Y8-M6-A25	Y9-M6-A25	Y19-M6-A25	M6 x 1,0	25,0
Y6-M6-A30	Y8-M6-A30	Y9-M6-A30	Y19-M6-A30	M6 x 1,0	30,0
Y6-M8-A10	Y8-M8-A10	Y9-M8-A10	Y19-M8-A10	M8 x 1,25	10,0
Y6-M8-A13	Y8-M8-A13	Y9-M8-A13	Y19-M8-A13	M8 x 1,25	12,0
Y6-M8-A16	Y8-M8-A16	Y9-M8-A16	Y19-M8-A16	M8 x 1,25	16,0
Y6-M8-A25	Y8-M8-A25	Y9-M8-A25	Y19-M8-A25	M8 x 1,25	25,0
Y6-M8-A30	Y8-M8-A30	Y9-M8-A30	Y19-M8-A30	M8 x 1,25	30,0
Y6-M8-A35	Y8-M8-A35	Y9-M8-A35	Y19-M8-A35	M8 x 1,25	35,0
Y6-M8-A40	Y8-M8-A40	Y9-M8-A40	Y19-M8-A40	M8 x 1,25	40,0
Y6-M8-A45	Y8-M8-A45	Y9-M8-A45	Y19-M8-A45	M8 x 1,25	45,0
Y6-M10-A13	Y8-M10-A13	Y9-M10-A13	Y19-M10-A13	M10 x 1,5	12,0
Y6-M10-A16	Y8-M10-A16	Y9-M10-A16	Y19-M10-A16	M10 x 1,5	16,0
Y6-M10-A20	Y8-M10-A20	Y9-M10-A20	Y19-M10-A20	M10 x 1,5	20,0
Y6-M10-A25	Y8-M10-A25	Y9-M10-A25	Y19-M10-A25	M10 x 1,5	25,0
Y6-M10-A30	Y8-M10-A30	Y9-M10-A30	Y19-M10-A30	M10 x 1,5	30,0
Y6-M10-A35	Y8-M10-A35	Y9-M10-A35	Y19-M10-A35	M10 x 1,5	35,0
Y6-M10-A40	Y8-M10-A40	Y9-M10-A40	Y19-M10-A40	M10 x 1,5	40,0



P1000



Material
Stainless steel DIN 1,4300.

Technical Notes
See tables on page 604 for individual machine screw dimensions.

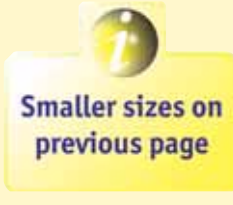

THREADED FASTENERS





P1002



Material
Stainless steel, DIN 1,4300. With nylon strip or pellet.

Technical Notes
See tables on page 604 for individual machine screw dimensions.

The nylon strip or pellet provides vibration proof self-locking of the screw.



Larger sizes on next page

THREADED FASTENERS



Long Lock and Nyloc Machine Screws

Stainless steel

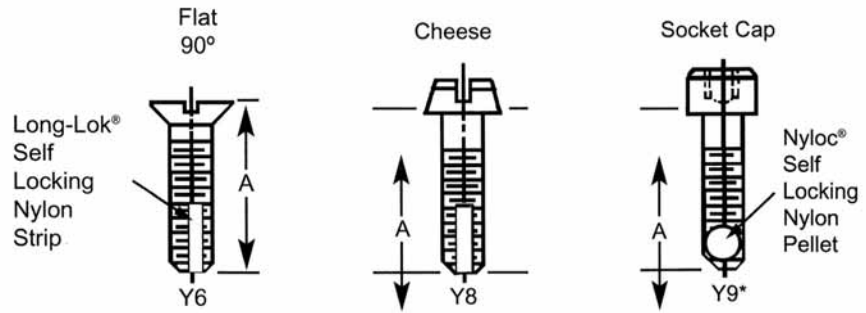

M5 to M10 on next page

Order No. Flat Head Long Lock	Order No. Cheese Head Long Lock	Order No. Socket Head Nyloc	Thread	Length A
Y6-M1-A4-L	Y8-M1-A4-L	Y9-M1-A4-N	M1,6 x 0,35	4,0
Y6-M1-A5-L	Y8-M1-A5-L	Y9-M1-A5-N	M1,6 x 0,35	5,0
Y6-M1-A6-L	Y8-M1-A6-L	Y9-M1-A6-N	M1,6 x 0,35	6,0
Y6-M1-A8-L	Y8-M1-A8-L	Y9-M1-A8-N	M1,6 x 0,35	8,0
Y6-M1-A10-L	Y8-M1-A10-L	Y9-M1-A10-N	M1,6 x 0,35	10,0
Y6-M2-A3-L	Y8-M2-A3-L	Y9-M2-A3-N	M2 x 0,4	3,0
Y6-M2-A4-L	Y8-M2-A4-L	Y9-M2-A4-N	M2 x 0,4	4,0
Y6-M2-A5-L	Y8-M2-A5-L	Y9-M2-A5-N	M2 x 0,4	5,0
Y6-M2-A6-L	Y8-M2-A6-L	Y9-M2-A6-N	M2 x 0,4	6,0
Y6-M2-A8-L	Y8-M2-A8-L	Y9-M2-A8-N	M2 x 0,4	8,0
Y6-M2-A10-L	Y8-M2-A10-L	Y9-M2-A10-N	M2 x 0,4	10,0
Y6-M2-A13-L	Y8-M2-A13-L	Y9-M2-A13-N	M2 x 0,4	12,0
Y6-M2-A16-L	Y8-M2-A16-L	Y9-M2-A16-N	M2 x 0,4	16,0
Y6-M2-A20-L	Y8-M2-A20-L	Y9-M2-A20-N	M2 x 0,4	20,0
Y6-M3-A5-L	Y8-M3-A5-L	Y9-M3-A5-N	M3 x 0,5	5,0
Y6-M3-A6-L	Y8-M3-A6-L	Y9-M3-A6-N	M3 x 0,5	6,0
Y6-M3-A8-L	Y8-M3-A8-L	Y9-M3-A8-N	M3 x 0,5	8,0
Y6-M3-A10-L	Y8-M3-A10-L	Y9-M3-A10-N	M3 x 0,5	10,0
Y6-M3-A13-L	Y8-M3-A13-L	Y9-M3-A13-N	M3 x 0,5	12,0
Y6-M3-A16-L	Y8-M3-A16-L	Y9-M3-A16-N	M3 x 0,5	16,0
Y6-M3-A20-L	Y8-M3-A20-L	Y9-M3-A20-N	M3 x 0,5	20,0
Y6-M3-A25-L	Y8-M3-A25-L	Y9-M3-A25-N	M3 x 0,5	25,0
Y6-M3-A30-L	Y8-M3-A30-L	Y9-M3-A30-N	M3 x 0,5	30,0
Y6-M4-A6-L	Y8-M4-A6-L	Y9-M4-A6-N	M4 x 0,7	6,0
Y6-M4-A8-L	Y8-M4-A8-L	Y9-M4-A8-N	M4 x 0,7	8,0
Y6-M4-A10-L	Y8-M4-A10-L	Y9-M4-A10-N	M4 x 0,7	10,0
Y6-M4-A13-L	Y8-M4-A13-L	Y9-M4-A13-N	M4 x 0,7	12,0
Y6-M4-A16-L	Y8-M4-A16-L	Y9-M4-A16-N	M4 x 0,7	16,0
Y6-M4-A20-L	Y8-M4-A20-L	Y9-M4-A20-N	M4 x 0,7	20,0
Y6-M4-A25-L	Y8-M4-A25-L	Y9-M4-A25-N	M4 x 0,7	25,0
Y6-M4-A30-L	Y8-M4-A30-L	Y9-M4-A30-N	M4 x 0,7	30,0
Y6-M4-A35-L	Y8-M4-A35-L	Y9-M4-A35-N	M4 x 0,7	35,0
Y6-M4-A40-L	Y8-M4-A40-L	Y9-M4-A40-N	M4 x 0,7	40,0

Long Lock and Nyloc Machine Screws

Stainless steel

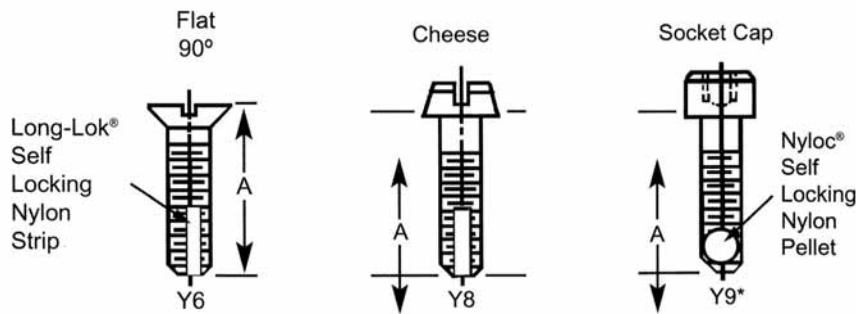

M1,6 to M4 on previous page

Order No. Flat Head Long Lock	Order No. Cheese Head Long Lock	Order No. Socket Head Nyloc	Thread	Length A
Y6-M5-A8-L	Y8-M5-A8-L	Y9-M5-A8-N	M5 x 0,8	8,0
Y6-M5-A10-L	Y8-M5-A10-L	Y9-M5-A10-N	M5 x 0,8	10,0
Y6-M5-A13-L	Y8-M5-A13-L	Y9-M5-A13-N	M5 x 0,8	12,0
Y6-M5-A16-L	Y8-M5-A16-L	Y9-M5-A16-N	M5 x 0,8	16,0
Y6-M5-A20-L	Y8-M5-A20-L	Y9-M5-A20-N	M5 x 0,8	20,0
Y6-M5-A25-L	Y8-M5-A25-L	Y9-M5-A25-N	M5 x 0,8	25,0
Y6-M5-A30-L	Y8-M5-A30-L	Y9-M5-A30-N	M5 x 0,8	30,0
Y6-M5-A35-L	Y8-M5-A35-L	Y9-M5-A35-N	M5 x 0,8	35,0
Y6-M5-A40-L	Y8-M5-A40-L	Y9-M5-A40-N	M5 x 0,8	40,0
Y6-M5-A50-L	Y8-M5-A50-L	Y9-M5-A50-N	M5 x 0,8	50,0
Y6-M6-A8-L	Y8-M6-A8-L	Y9-M6-A8-N	M6 x 1,0	8,0
Y6-M6-A10-L	Y8-M6-A10-L	Y9-M6-A10-N	M6 x 1,0	10,0
Y6-M6-A12-L	Y8-M6-A12-L	Y9-M6-A12-N	M6 x 1,0	12,0
Y6-M6-A16-L	Y8-M6-A16-L	Y9-M6-A16-N	M6 x 1,0	16,0
Y6-M6-A20-L	Y8-M6-A20-L	Y9-M6-A20-N	M6 x 1,0	20,0
Y6-M6-A25-L	Y8-M6-A25-L	Y9-M6-A25-N	M6 x 1,0	25,0
Y6-M6-A30-L	Y8-M6-A30-L	Y9-M6-A30-N	M6 x 1,0	30,0
Y6-M8-A10-L	Y8-M8-A10-L	Y9-M8-A10-N	M8 x 1,25	10,0
Y6-M8-A13-L	Y8-M8-A13-L	Y9-M8-A13-N	M8 x 1,25	12,0
Y6-M8-A16-L	Y8-M8-A16-L	Y9-M8-A16-N	M8 x 1,25	16,0
Y6-M8-A20-L	Y8-M8-A20-L	Y9-M8-A20-N	M8 x 1,25	20,0
Y6-M8-A25-L	Y8-M8-A25-L	Y9-M8-A25-N	M8 x 1,25	25,0
Y6-M8-A30-L	Y8-M8-A30-L	Y9-M8-A30-N	M8 x 1,25	30,0
Y6-M8-A35-L	Y8-M8-A35-L	Y9-M8-A35-N	M8 x 1,25	35,0
Y6-M8-A40-L	Y8-M8-A40-L	Y9-M8-A40-N	M8 x 1,25	40,0
Y6-M8-A45-L	Y8-M8-A45-L	Y9-M8-A45-N	M8 x 1,25	45,0
Y6-M10-A13-L	Y8-M10-A13-L	Y9-M10-A13-N	M10 x 1,5	12,0
Y6-M10-A16-L	Y8-M10-A16-L	Y9-M10-A16-N	M10 x 1,5	16,0
Y6-M10-A20-L	Y8-M10-A20-L	Y9-M10-A20-N	M10 x 1,5	20,0
Y6-M10-A25-L	Y8-M10-A25-L	Y9-M10-A25-N	M10 x 1,5	25,0
Y6-M10-A30-L	Y8-M10-A30-L	Y9-M10-A30-N	M10 x 1,5	30,0
Y6-M10-A35-L	Y8-M10-A35-L	Y9-M10-A35-N	M10 x 1,5	35,0
Y6-M10-A40-L	Y8-M10-A40-L	Y9-M10-A40-N	M10 x 1,5	40,0



P1002



Material
Stainless steel, DIN 1,4300. With nylon strip or pellet.

Technical Notes

See tables on page XX for individual machine screw dimensions.

The nylon strip or pellet provides vibration proof self-locking of the screw.



Smaller sizes on previous page

THREADED FASTENERS



P100092 Machine Screws

technical data

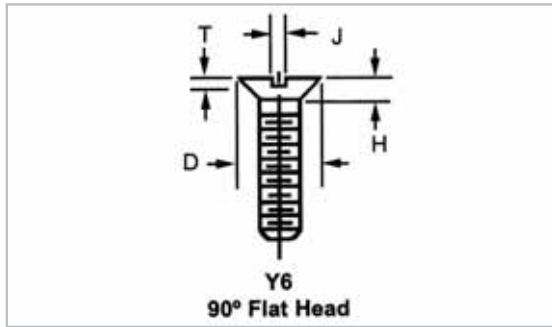

Screw Size	Y6-Flat Head 92°			
	D	H Max	J	T Min
M 1,6	3,0	1,0	0,4	0,3
M 2,0	3,8	1,2	0,5	0,4
M 3,0	5,6	1,7	0,8	0,6
M 4,0	7,5	2,2	1,0	0,8
M 5,0	9,2	2,5	1,2	1,0
M 6,0	11,0	3,0	1,6	1,2
M 8,0	14,5	4,0	2,0	1,6
M 10,0	18,0	5,0	2,5	2,0

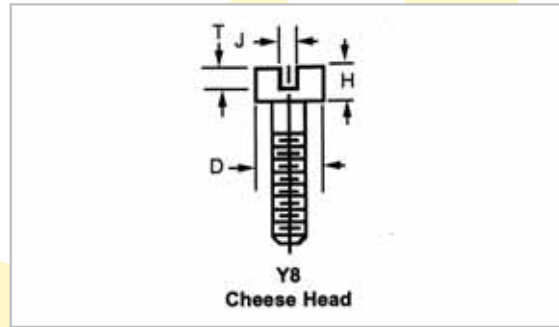

Screw Size	Y8-Cheese Head			
	D	H Max	J	T Min
M 1,6	3,0	1,0	0,4	0,5
M 2,0	3,8	1,3	0,5	0,6
M 3,0	5,5	2,0	0,8	0,9
M 4,0	7,0	2,6	1,0	1,2
M 5,0	8,5	3,3	1,2	1,5
M 6,0	10,0	3,9	1,6	1,8
M 8,0	13,0	5,0	2,0	2,3
M 10,0	16,0	6,0	2,5	2,7

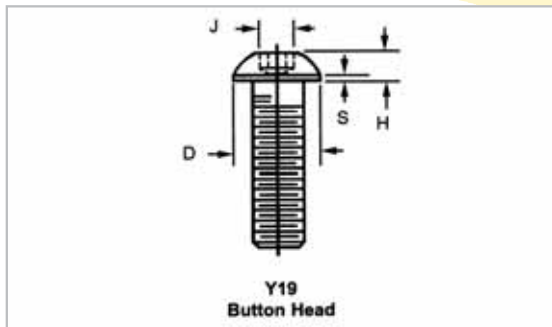

Nominal Size	Y-19 Button Head			
	D Max	H Max	S Ref	J Nom
M3	5,50	1,60	0,38	2,00
M4	7,50	2,10	0,38	2,50
M5	9,50	2,70	0,50	3,00
M6	10,50	3,20	0,80	4,00
M8	14,00	4,30	0,80	5,00
M10	18,00	5,30	0,80	6,00
-	-	-	-	-

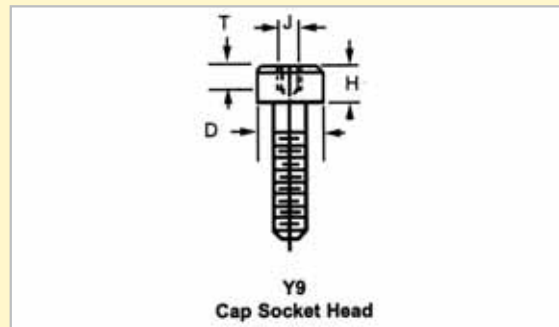

Screw Size	Y-9 Cap Socket Head			
	D	H Max	J Across Flats	T Min
M 1,6	3,0	1,6	1,5	0,7
M 2,0	3,8	2,0	1,5	1,0
M 3,0	5,5	3,0	2,5	1,3
M 4,0	6,0	4,0	3,0	2,0
M 5,0	8,5	5,0	4,0	2,5
M 8,0	13,0	8,0	6,0	4,0
M 10,0	16,0	10,0	8,0	5,0

THREADED FASTENERS