

Double Flange Timing Pulleys - circ. pitch 3,0mm HTD for belts width 6-9mm

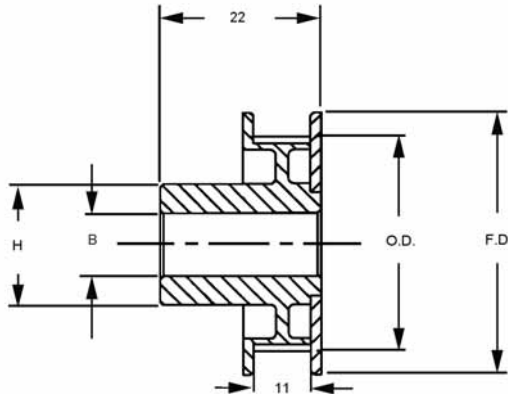

Order No.	Bore +0,036 -0,000	No. of teeth	O.D. Ø	P.D. Ø	F.D. Ø	H
TP3L4W9M-17	4,0	17	15,4	16,2	22	17
TP3L4W9M-18	4,0	18	16,4	17,2	24	17
TP3L4W9M-19	4,0	19	17,4	18,2	24	17
TP3L4W9M-20	4,0	20	18,3	19,1	24	17
TP3L4W9M-22	4,0	22	20,2	21,0	27	17
TP3L6W9M-25	6,0	25	23,1	23,9	30	19
TP3L6W9M-28	6,0	28	26,0	26,8	32	19
TP3L6W9M-32	6,0	32	29,8	30,6	32	19
TP3L6W9M-36	6,0	36	33,6	34,4	40	22
TP3L6W9M-40	6,0	40	37,4	38,2	45	22
TP3L6W9M-48	6,0	48	45,0	45,8	51	22
TP3L8W9M-60	8,0	60	56,5	57,3	63	22
TP3L8W9M-72	8,0	72	68,0	68,8	74	22
TP3L8W9M-80	8,0	80	75,6	76,4	84	22



R1470



Material

Polycarbonate Lexan with fibreglass reinforcement 94 V-0 UL rated.

Lexan material specs:

Tensile strength (PSI) 16,000.
Compressive strength (PSI) 16,000.
Flexural strength (PSI) 19,000.
Impact (ft-lbs/in notch) 2,0.
Water absorption (24 hrs) Equilibrium 73% 0.29%.

Technical Notes

- All flanges 1/16" thick.
- One or two set screws are optional.
- Examples of specials:
 - a. Bores - D shaped, key slots, square or spline.
 - b. Face widths other than standard.
 - c. Hubless or hub diameters other than standard.
 - d. Aluminium, brass or stainless steel inserts through bore and pulley overmoulded.
 - e. Non standard bores are available on request.

Important Notes

Operates with TB3 (R1430 & R1431) timing belts.

BELTS & PULLEYS

