

Knurled Thumb Nuts

stainless steel A4

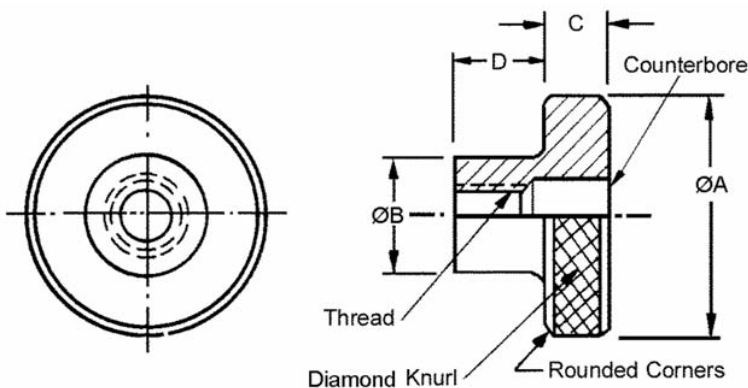

P1084



Material

Stainless steel A4 (DIN 1,4305
AISI 316).

Technical Notes

Stainless steel thumb screws A4 are considerably more expensive than A2 stainless steel thumb screws. They are highly resistant to corrosion.



**Imperial threads
readily available
on request**

Order No.	Thread	ØA	B	ØC	D	Counterbore Dia.	Counterbore Deep
P1084.031	M3	12,0	6,0	3,0	6,0	-	-
P1084.032	M3	12,0	6,0	3,0	12,0	3,2	6,0
P1084.035	M3	19,0	6,0	3,0	6,0	-	-
P1084.036	M3	19,0	6,0	3,0	12,0	3,2	6,0
P1084.041	M4	12,0	8,0	3,0	6,0	-	-
P1084.042	M4	12,0	8,0	3,0	12,0	4,2	6,0
P1084.045	M4	19,0	8,0	3,0	6,0	-	-
P1084.046	M4	19,0	8,0	3,0	12,0	4,2	6,0
P1084.051	M5	12,0	10,0	5,0	6,0	-	-
P1084.052	M5	12,0	10,0	5,0	12,0	5,3	7,5
P1084.055	M5	25,5	10,0	5,0	6,0	-	-
P1084.056	M5	25,0	10,0	5,0	12,0	5,3	7,5
P1084.061	M6	19,0	12,5	6,5	6,0	-	-
P1084.062	M6	19,0	12,5	6,5	12,0	6,4	9,0
P1084.065	M6	25,5	12,5	6,5	6,0	-	-
P1084.066	M6	25,5	12,5	6,5	12,0	6,4	9,0
P1084.067	M6	25,5	12,5	6,5	19,0	6,4	15,0

THREADED FASTENERS

linear and rotary motion components
Automation
