

# Brass Soft Tip Set Screws

hexagon socket head

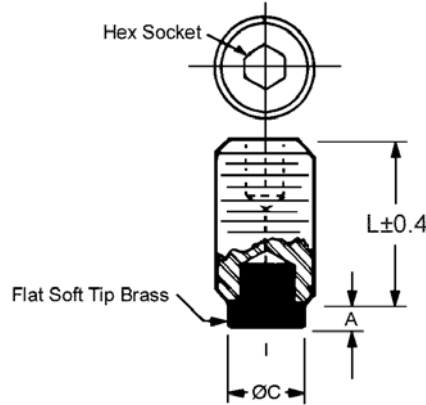

## P1020

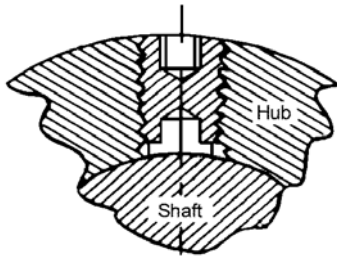

### Material

Stainless steel (AISI 302, DIN1.4300) or heat treated alloy steel (black oxide finish). Brass tip.

### Technical Notes

Non marring, self-locking. Also used as position adjustment screw. Screws may be re-used. Conforms to shaft or part surface for positive grip. Length is exclusive of brass tip.

### Tips

302 stainless steel provides good resistance to corrosion, it is soft and non-magnetic. Typically used in food and pharmaceutical applications. 302 stainless steel is not suitable for use in marine environments.

Order No.	Thread	L	C	A	Material
P1020.03-03	M3	3,0	1,6	0,8	Stainless steel
P1020.03-06	M3	6,0	1,6	0,8	Stainless steel
P1020.03-09	M3	9,0	1,6	0,8	Stainless steel
P1020.04-04	M4	4,0	2,4	1,2	Stainless steel
P1020.04-06	M4	6,0	2,4	1,2	Stainless steel
P1020.04-10	M4	10,0	2,4	1,2	Stainless steel
P1020.05-06	M5	6,0	2,4	1,2	Stainless steel
P1020.05-10	M5	10,0	2,4	1,2	Stainless steel
P1020.05-16	M5	16,0	2,4	1,2	Stainless steel
P1020.06-06	M6	6,0	3,2	1,6	Alloy steel
P1020.06-16	M6	16,0	3,2	1,6	Alloy steel
P1020.06-25	M6	25,0	3,2	1,6	Alloy steel
P1020.08-06	M8	6,0	3,2	1,6	Alloy steel
P1020.08-10	M8	10,0	3,2	1,6	Alloy steel
P1020.08-16	M8	16,0	3,2	1,6	Alloy steel
P1020.08-25	M8	25,0	3,2	1,6	Alloy Steel
P1020.10-10	M10	10,0	4,8	2,4	Alloy Steel
P1020.10-16	M10	16,0	4,8	2,4	Alloy Steel
P1020.10-25	M10	25,0	4,8	2,4	Alloy steel

