

Stainless Steel Set Screw

slotted and socket head

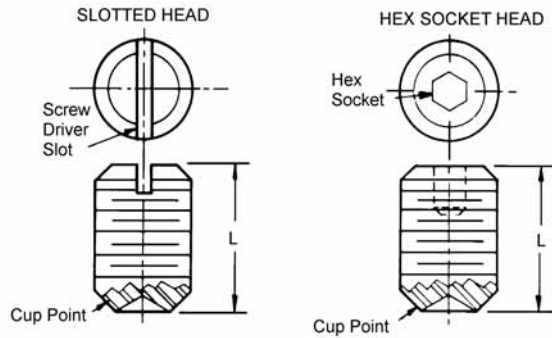

P1006



Material
Stainless steel 304.

Order No. Slot	Order No. Hex.	Thread Size	Length
SC1M-1	SC2M-1	M1,6 x 0,35	3,0
SC1M-2	SC2M-2	M1,6 x 0,35	4,0
SC1M-3	SC2M-3	M1,6 x 0,35	5,0
SC1M-4	SC2M-4	M2,0 x 0,40	3,0
SC1M-5	SC2M-5	M2,0 x 0,40	4,0
SC1M-6	SC2M-6	M2,0 x 0,40	5,0
SC1M-7	SC2M-7	M2,0 x 0,40	6,0
SC1M-8	SC2M-8	M3,0 x 0,50	3,0
SC1M-9	SC2M-9	M3,0 x 0,50	4,0
SC1M-10	SC2M-10	M3,0 x 0,50	5,0
SC1M-11	SC2M-11	M3,0 x 0,50	6,0
SC1M-12	SC2M-12	M4,0 x 0,70	4,0
SC1M-13	SC2M-13	M4,0 x 0,70	6,0
SC1M-14	SC2M-14	M4,0 x 0,70	10,0
SC1M-15	SC2M-15	M4,0 x 0,70	14,0
SC1M-16	SC2M-16	M5,0 x 0,80	6,0
SC1M-17	SC2M-17	M5,0 x 0,80	10,0
SC1M-18	SC2M-18	M5,0 x 0,80	14,0
SC1M-19	SC2M-19	M5,0 x 0,80	20,0
SC1M-20	SC2M-20	M6,0 x 1,00	6,0
SC1M-21	SC2M-21	M6,0 x 1,00	10,0
SC1M-22	SC2M-22	M6,0 x 1,00	16,0
SC1M-23	SC2M-23	M6,0 x 1,00	25,0
SC1M-28	SC2M-28	M8,0 x 1,25	10,0
SC1M-29	SC2M-29	M8,0 x 1,25	16,0
SC1M-30	SC2M-30	M8,0 x 1,25	25,0
SC1M-24	SC2M-24	M10,0 x 1,50	12,0
SC1M-25	SC2M-25	M10,0 x 1,50	20,0
SC1M-26	SC2M-26	M10,0 x 1,50	30,0

THREADED FASTENERS



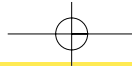

Threaded Fasteners - Product Showcase



P1000
Machine screws.

P1002
Machine screws with long-lok.



P1010
Integral seal screws.



P1020
Brass tipped screws.



P1024
Nylon tipped screws.



P1030
Shoulder screws.



P1035
Captive screws.



P1040
Thumb screws.



P1044
Thumb screws.



P1052
Stainless thread.



P1080
Cam cleats.



P1110
Threaded spacers-female.



P1120
Threaded spacers, male - female.

Imperial sizes and other fasteners readily available

THREADED FASTENERS

