

POSITIONING STAGES



L1165



Material
Body from 6061 aluminium alloy - provides a light, yet stiff and stable stage.

Technical Notes
The design utilises a thrust bearing system for the table movement. This offers excellent stability at low cost. The stages are offered with different gear ratio options. A proprietary preload system ensures zero backlash in the gear train. The travel is 360° continuous.

Tips
Suitable for a wide range of uses from lightweight positioning of optics to light duty machine tool applications.

Accurate and value for money rotary tables. Rotary bearings also available (see R4000 to R4240).

Get the latest on our new linear rail systems

Call 01483 286674 for your Free Catalogue

Automotion

linear and rotary motion

Rotary tables Ø125mm table (approx.)

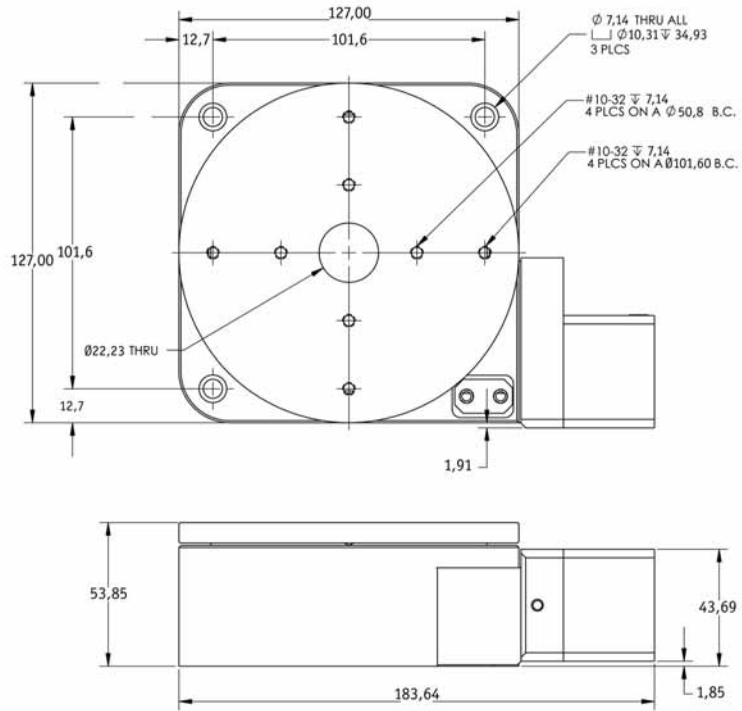

Order No.	Control	Repeatability arc-secs	Resolution arc-secs	Gear Ratio	Motor size	Max. load Kg.	Moment Nm	Max. input speed rpm	Travel Cont.	kg
RT5-M17	Motor	5	0,36	72:1	Nema 17	45	10,8	1200	360°	2,3
RT5-DR	Manual	5	0,36	72:1	-	45	10,8	1200	360°	2,3



Positioning Stages - Rotary L1163-69

Quality and cost-effective rotary tables with stepper motors



POSITIONING STAGES

RT Series

- ⊙ Offers a high resolution and repeatability
- ⊙ Medium load capacity
- ⊙ Table size: Ø50 to Ø125mm.
- ⊙ Suitable for lightweight positioning to light duty machine tool applications
- ⊙ Uses a thrust bearing system for the table movement. This provides excellent stability at low cost.
- ⊙ The units are offered with different gear ratio options.

RM Series

- ⊙ Offers high resolution and repeatability.
- ⊙ Table size: Ø75 to Ø200mm.
- ⊙ Suitable for lightweight positioning to heavy duty machine tool applications.
- ⊙ Uses a single pre-loaded roller bearing for the table movement, which eliminates the use of a dual bearing configuration, thus improving axial run-out and wobble.
- ⊙ The units are offered with different gear ratio options.



RT-2
Compact Design.
Ø50mm table.



RM-3
Compact design.
Ø75mm table.



RT-3
Low cost.
Ø75mm table.



RM-5
Low cost.
Ø125mm table.
RM-5
Sealed unit option (L1168)
Ø125mm table.



RT-5
Low profile.
Ø125mm table.



RM-8
High load capacity belt or direct drive.
Ø200mm table.



DRO Versions
Any of the RT series with manual control with digital read out.



DRO Versions
Any of the RM series with manual control with digital read out.



Positioning Stages - Motion Controllers

for stages L1160 & L1161



L1162



POSITIONING STAGES

Order No.	No. of axis control	Encoder
NSC-1S	Single	No
NSC-1S-E	Single	Yes
NSC-1H	Single	No
NSC-1H-E	Single	Yes
NSC-M2	Two	No
NSC-M2-E	Two	Yes
NSC-M3	Three	No
NSC-M4	Four	No

Specification - NSC-1 Series

Output current NSC-1S	2A Typ., 4A peak (programmable to lower current settings)
Output Current NSC-1H	3A Typ., 6A peak (programmable to lower current settings)
Motor type	2/4 phase bipolar stepper
MicrostepResolution	Programmable up to 51200 steps per rev (1,8° motor)
Communications	RS-232, 4800 to 38,8kbps
User programme space	8175 bytes
Program and data storage	Flash
Number of I/O	6 (software selectable as dedicated or general purpose)
Encoder feedback	High speed differential inputs
Encoder functions	Stall detection and position maintenance

Technical Notes

NSC-1:

A powerful single axis machine control system combining a bipolar microstepping driver with a programmable controller in a compact envelope.

The motion controller can operate as a stand alone system through the RS-232 port. It utilizes a 32-bit microprocessor to control the trajectory, profile, acceleration, velocity and deceleration.

If closed loop the NSC-1 can be expanded to handle different inputs from an encoder.

NSC-M Series:

The controller can communicate with the host computer through an RS232 interface. It can manage up to four axis and perform co-ordinated or independent motion of each or all of the axis simultaneously.

With built-in high level functionality, such as circular and linear interpolation, multi-tasking and custom profiling the controller is greatly simplified.

The multi-axis controller is commanded using virtually any programming language to pass simple ASCII command strings to the controller through the RS-232 port.



L1160-62 Positioning Stages

Motorised

POSITIONING STAGES

L1160 - Type NB-4

Specification - NB4

	Type	Accuracy
Resolution	1,5748mm/ rev lead	0,03µm @50,000 steps/ rev motor resolution
Resolution	6,35mm/ rev lead	0,13µm @50,000 steps/ rev motor resolution
Resolution	1,5748mm/ rev lead with encoder	0,8µm @2,000 counts/ rev encoder resolution (-E option) 0,4µm @4,000 counts/ rev encoder resolution (-E1 option)
Resolution	1,35mm/ rev lead with encoder	3,2µm @2,000 counts/ rev encoder resolution (-E option) 1,6µm @4,000 counts/ rev encoder resolution (-E1 option)
Max. Travel Speed	1,5748mm/ rev lead	12,7mm/ second
Max. Travel Speed	6,35mm/ rev lead	50,8mm/ second
Repeatability Bidirectional		±5µm

Specification - NB4

Motor Connection		Signal Connection		Signal Connection (encoder option)	
DB9 male	Description	DB9 female	Description	HD-15 female	Description
1	Phase A	1	Positive limit	1	Positive limit switch
2	Phase A'	2	Negative limit	2	Negative limit switch
3	Phase B	3	Gnd	3	Gnd (limits)
4	Phase B'	4	NC	4	Gnd (encoder)
5	A centre tap	5	NC	5	+5V
6	A centre tap	6	NC	6	Ch. A
7	NC	7	NC	7	Ch. A-
8	NC	8	NC	8	Ch. B
9	NC	9	NC	9	Ch. B-
				10	Index
				11	Index-

L1161 - Type NLS-4

Specification - NLS4

	Type	Accuracy
Resolution	1,5748mm/ rev lead	0,03µm @50,000 steps/ rev motor resolution
Resolution	6,35mm/ rev lead	0,13µm @50,000 steps/ rev motor resolution
Resolution	1,5748mm/ rev lead with encoder	0,8µm @2,000 counts/ rev encoder resolution (-E option) 0,4µm @4,000 counts/ rev encoder resolution (-E1 option)
Resolution	6,35mm/ rev lead with encoder	3,2µm @2,000 counts/ rev encoder resolution (-E option) 1,6µm @4,000 counts/ rev encoder resolution (-E1 option)
Max. Travel Speed	1,5748mm/ rev lead	12,7mm/ second
Max. Travel Speed	6,35mm/ rev lead	50,8mm/ second
Repeatability Bidirectional		±0,5µm

Specification - NLS-4

Motor Connection		Signal Connection		Signal Connection (encoder option)	
DB9 male	Description	DB9 female	Description	HD-15 female	Description
1	Phase A	1	Positive limit	1	Positive limit switch
2	Phase A'	2	Negative limit	2	Negative limit switch
3	Phase B	3	Gnd	3	Gnd (limits)
4	Phase B'	4	NC	4	Gnd (encoder)
5	A centre tap	5	NC	5	+5V
6	A centre tap	6	NC	6	Ch. A
7	NC	7	NC	7	Ch. A-
8	NC	8	NC	8	Ch. B
9	NC	9	NC	9	Ch. B-
				10	Index
				11	Index-